

## General Description

AOZ13937DI is protection switch intended for applications that require reverse current protection. The input operating voltage range is from 3.4V to 32V, and both VIN and VOUT terminals are rated at 39V absolute maximum. The power switch is capable for 20A surge current for 10ms. AOZ13937DI provides under-voltage lockout, over-voltage, reverse-current, and over-temperature protection. The FLTB pin flags thermal shutdown and over-voltage faults.

AOZ13937DI is the ideal solution for multi-port Type-C PD current application. The Ideal Diode True Reverse Current Blocking (IDTRCB) feature prevents VIN to rise due to reverse current flow from VOUT under all conditions.

An internal soft-start circuit controls inrush current due to highly capacitive loads and the slew rate can be adjusted using an external capacitor. The integrated back-to-back MOSFET offer industry's lowest ON resistance and highest SOA to safely handle high current and wide range of output capacitances on VOUT.

The AOZ13937DI is available in a thermally enhanced 3mm x 3mm DFN-12L package which can operate over -40 °C to +125 °C junction temperature range.

## Features

- 8A continuous current
- 20A peak current for 10 ms @ 2% duty cycle
- 20 mΩ typical ON resistance
- 3.4V to 32V operating input voltage
- VIN and VOUT are rated 39V Abs max
- Ideal Diode True Reverse Current Blocking (IDTRCB)
- Programmable Soft-Start
- VIN Under-Voltage Lockout (UVLO)
- Programmable VIN Over-Voltage Lockout (OVLO)
- Thermal Shutdown Protection
- Startup Short Circuit Protection
- Fault Recovery
  - AOZ13937DI-01: Auto-Restart
  - AOZ13937DI-02: Latch-Off
- IEC 61000-4-2: ±8kV contact discharge, ±15kV air discharge on VIN and VOUT
- IEC 61000-4-5: 45V on VIN and VOUT, no Cap

## Applications

- Thunderbolt/USB Type-C PD power switch
- Notebook Computers
- Docking Stations / Dongles
- Power ORing Applications



## Typical Application

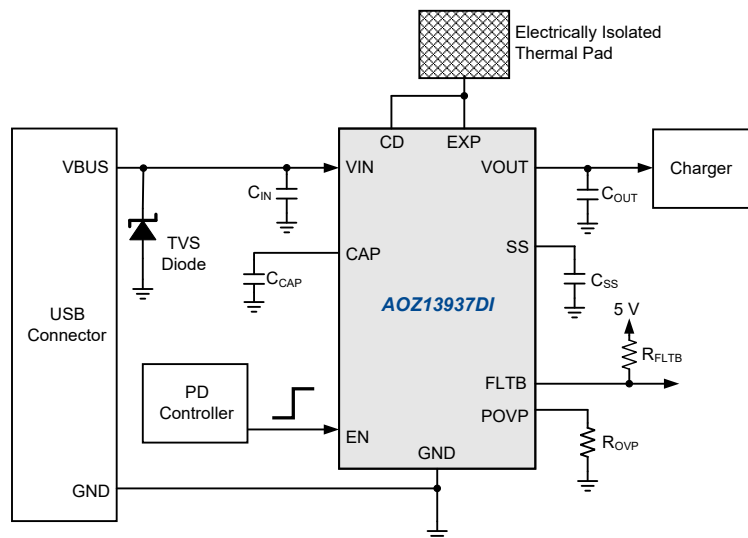

## Ordering Information

Part Number	Fault Recovery	Junction Temperature Range	Package	Environmental
AOZ13937DI-01	Auto-Restart	-40 °C to +125 °C	DFN3x3-12L	RoHS
AOZ13937DI-02	Latch-Off	-40 °C to +125 °C	DFN3x3-12L	RoHS



AOS products are offered in packages with Pb-free plating and compliant to RoHS standards.

Please visit <https://aosmd.com/sites/default/files/media/AOSGreenPolicy.pdf> for additional information.

## Pin Configuration

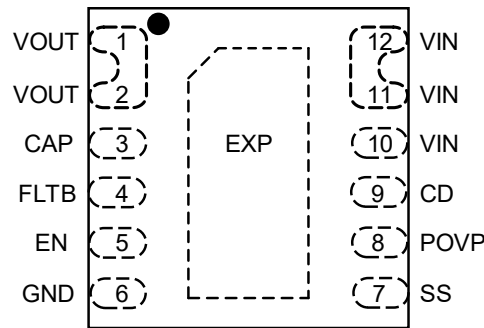

DFN3x3-12L  
(Top Transparent View)

## Pin Description

Pin Number	Pin Name	Pin Function
1, 2	VOUT	Output pins. Connect to internal load.
3	CAP	Connect a 1 nF capacitor to GND.
4	FLTB	Fault Indicator, Open-drain output. Pull low after a fault condition is detected.
5	EN	Enable Active High.
6	GND	Ground.
7	SS	Soft-start pin. Connect a capacitor CSS from SS to GND to set the soft-start time.
8	POVP	Over Voltage Protection Setting. Connect a resistor or direct DC voltage to determine the OVP threshold
9	CD	Common Drain node for the power switches and it must be electrically connected to EXP
10, 11, 12	VIN	Connect to adapter or power input. Place a 10 µF capacitor from VIN to GND.
EXP	EXP	Exposed Thermal Pad. It is the common drain node for the power switches and it must be electrically isolated. Solder to a metal surface directly underneath the EXP and connect to floating copper thermal pads on multiple PCB layers through many VIAs. For best thermal performance, make the floating copper pads as large as possible.

## Absolute Maximum Ratings

Exceeding the Absolute Maximum ratings may damage the device.

Parameter	Rating
V <sub>IN</sub> , V <sub>OUT</sub> to GND	-0.3V to +39V
EN, SS, FLTB, POVP to GND	-0.3V to +6V
CAP to VIN	-0.3V to +6V
Junction Temperature (T <sub>J</sub> )	+150 °C
Storage Temperature (T <sub>S</sub> )	-65 °C to +150 °C
ESD Rating HBM All Pins	±2 kV
IEC 61000-4-2: VIN and VOUT Pins	±8 kV contact discharge ±15 kV air discharge

## Recommended Operating Conditions

The device is not guaranteed to operate beyond the Maximum Recommended Operating Conditions.

Parameter	Rating
Supply Voltage V <sub>IN</sub>	3.4V to 32V
EN, FLTB	0V to 5.5V
SS, POVP	0V to 3V
CAP to VIN	0V to 5.5V
DC Fully On Switch Current (I <sub>SW</sub> )	0V to 8A
Peak Switch Current (I <sub>SW</sub> ) for 10 ms @ 2% Duty Cycle	20A
Junction Temperature (T <sub>J</sub> )	-40 °C to +125 °C

## Electrical Characteristics

T<sub>A</sub> = 25 °C, V<sub>IN</sub> = 28 V, EN = 5V, C<sub>CAP</sub> = 1 nF, C<sub>IN</sub> = 10 μF, C<sub>OUT</sub> = 10 μF, C<sub>SS</sub> = 5.6 nF, POVP=1V, unless otherwise specified.

Symbol	Parameter	Conditions	Min	Typ	Max	Units
<b>General</b>						
V <sub>VIN</sub>	Input Supply Voltage		3.4		32	V
V <sub>UVLO</sub>	Under-voltage Lockout Threshold	V <sub>IN</sub> rising	3.0		3.35	V
V <sub>UVLO_HYS</sub>	Under-voltage Lockout Hysteresis			300		mV
I <sub>VIN_ON</sub>	Input Quiescent Current	I <sub>OUT</sub> = 0 A		650		μA
I <sub>VIN_OFF</sub>	Input Shutdown Current	I <sub>OUT</sub> = 0 A, EN = 0 V		75	105	μA
I <sub>VOUT_OFF</sub>	Output Leakage Current	V <sub>OUT</sub> = 32 V, V <sub>IN</sub> = 0 V, EN = 0 V		45		μA
R <sub>ON_20V</sub>	Switch ON-Resistance <sup>(1)</sup>	V <sub>IN</sub> = 20V, I <sub>OUT</sub> = 1 A		20		mΩ
R <sub>ON_5V</sub>		V <sub>IN</sub> = 5V, I <sub>OUT</sub> = 1 A		22		mΩ
V <sub>EN_H</sub>	EN Input High Threshold	EN rising			1.4	V
V <sub>EN_L</sub>	EN Input Low Threshold	EN falling	0.6			V
V <sub>EN_HYS</sub>	EN Input Hysteresis			350		mV
R <sub>EN_LO</sub>	EN Input Pull-down Resistance		475	730	985	kΩ
V <sub>FLTB_LO</sub>	FLTB Pin Pull-down Voltage	FLTB sinking 3 mA			0.3	V
<b>Input Over-Voltage Protection</b>						
V <sub>OVP</sub>	Over-Voltage Protection Threshold	POVP < 1.25 V	33	34	35.6	V
		POVP > 1.4 V	23	24	25	
I <sub>POVP</sub>	POVP Current			5		μA
t <sub>OVP_DEB</sub>	Over-Voltage Protection Debounce Time			512		μs
<b>Idea Diode True Reverse Current Blocking</b>						
V <sub>IDTRCB</sub>	Ideal Diode TRCB Regulation Voltage	V <sub>IN</sub> – V <sub>OUT</sub>		35		mV

### Note:

1. Switch On-Resistance test under test mode condition

### Electrical Characteristics

T<sub>A</sub> = 25°C, VIN = 28V, EN = 5V, C<sub>CAP</sub> = 1 nF, C<sub>IN</sub> = 10 μF, C<sub>OUT</sub> = 10 μF, C<sub>SS</sub> = 5.6 nF, POVP=1V, unless otherwise specified.

Symbol	Parameter	Conditions	Min	Typ	Max	Units
<b>Dynamic Timing Characteristics</b>						
t <sub>D_ON</sub>	Turn-On Delay Time	From EN rising edge to VOUT reaching 10% of VIN		9		ms
t <sub>ON</sub>	Turn-On Rise Time	VOUT from 10% to 90%		1.8		ms
t <sub>SCP_REC_01</sub>	Auto Restart Interval upon Startup Short Circuit Condition	AOZ13937DI-01 Only		64		ms
t <sub>SCP_REC_02</sub>	Auto Restart Delay at Each Retry upon Startup Short Circuit Condition	AOZ13937DI-02 Only. System latch off after 4 times retry.		2		ms
<b>Thermal Shutdown Protection</b>						
T <sub>SD</sub>	Thermal Shutdown Threshold	Temperature rising		140		°C
T <sub>SD_HYS</sub>	Thermal Shutdown Hysteresis	Temperature falling, AOZ13937DI-01 only		30		°C

### Thermal Characteristics

Symbol	Parameter	Conditions	Min	Typ	Max	Units
R <sub>th(J-C), bottom</sub>	Thermal Resistance from junction to case bottom			2.5		°C/W
R <sub>th(J-A)</sub>	Thermal Resistance from junction to ambient <sup>(2)</sup>			36		°C/W

**Note:**

2. R<sub>th(J-A)</sub> is dependent upon board layout. To minimize, ensure all pins have a solid connection to larger copper layer areas

### Functional Block Diagram

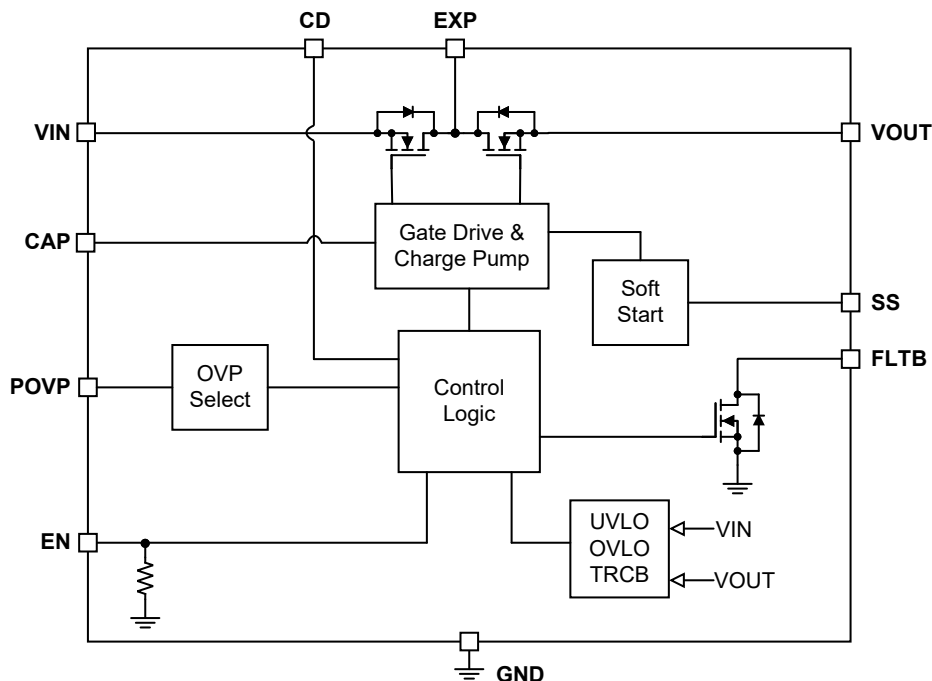

## Timing Diagrams

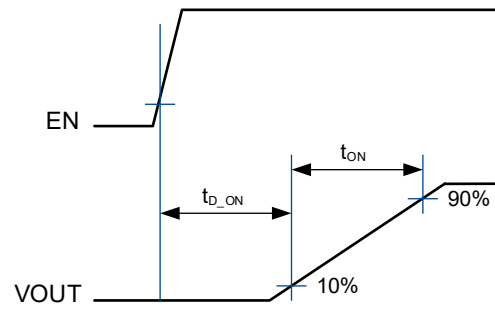

Figure 1. Turn-on Delay and Turn-on Time

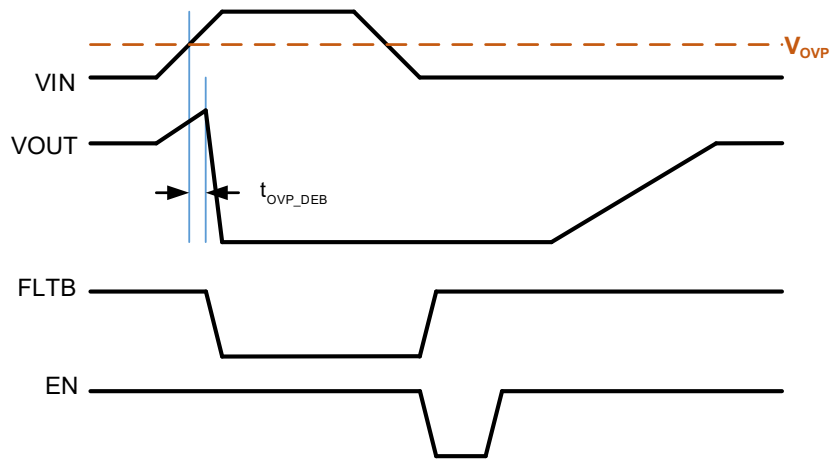
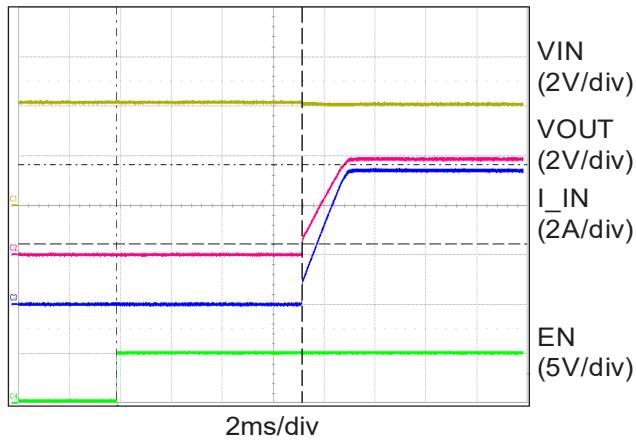

Figure 2. Over-Voltage Protection (AOZ13937DI-02)

## Typical Characteristics

$T_A = 25\text{ }^\circ\text{C}$ ,  $V_{IN} = 28\text{ V}$ ,  $EN = 5\text{ V}$ ,  $C_{IN} = 10\text{ }\mu\text{F}$ ,  $C_{OUT} = 10\text{ }\mu\text{F}$ ,  $C_{SS} = 5.6\text{ nF}$ ,  $C_{CAP} = 1\text{ nF}$ ,  $POVP=1V$ , unless otherwise specified.

**Soft Start Delay Time**  
( $V_{IN} = 4\text{ V}$ ,  $R_{OUT} = 0.77\text{ }\Omega$ )



**Soft Start Delay Time**  
( $V_{IN} = 28\text{ V}$ ,  $R_{OUT} = 4\text{ }\Omega$ )

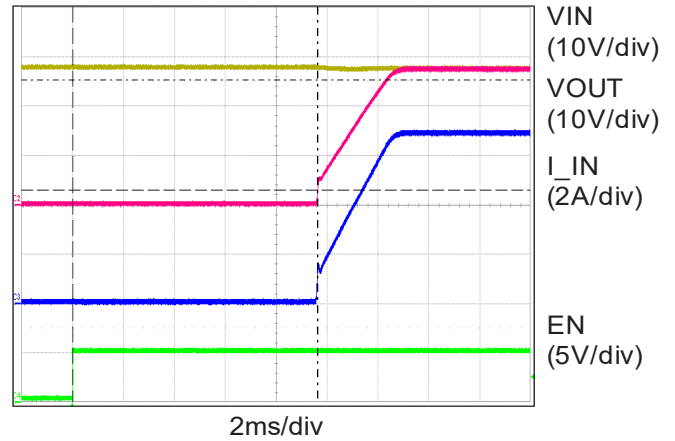

**Soft Start Ramp**  
( $V_{IN} = 4\text{ V}$ ,  $R_{OUT} = 0.77\text{ }\Omega$ )

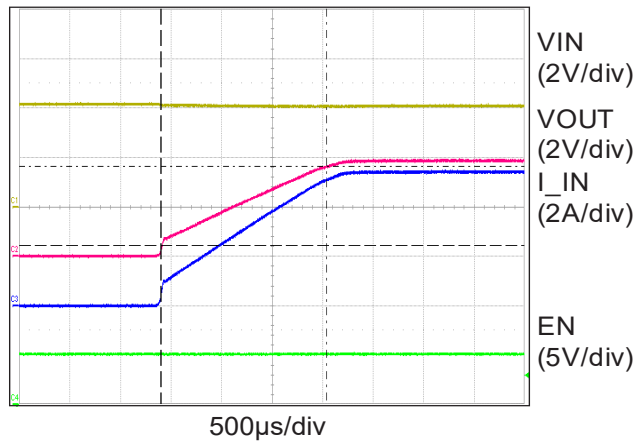

**Soft Start Ramp**  
( $V_{IN} = 28\text{ V}$ ,  $R_{OUT} = 4\text{ }\Omega$ )

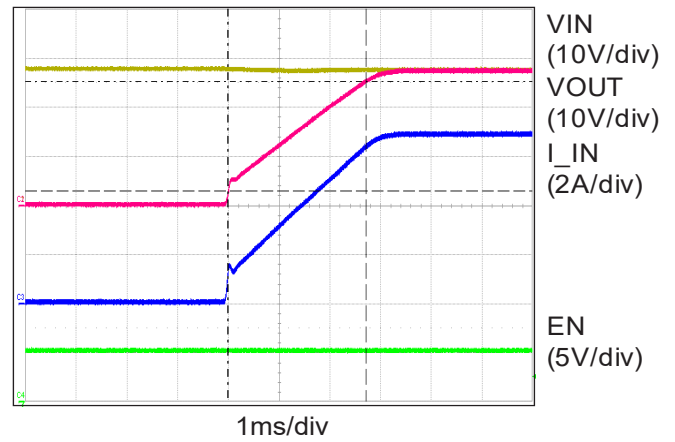

**Shut Down**  
( $V_{IN} = 4\text{ V}$ ,  $R_{OUT} = 0.77\text{ }\Omega$ )

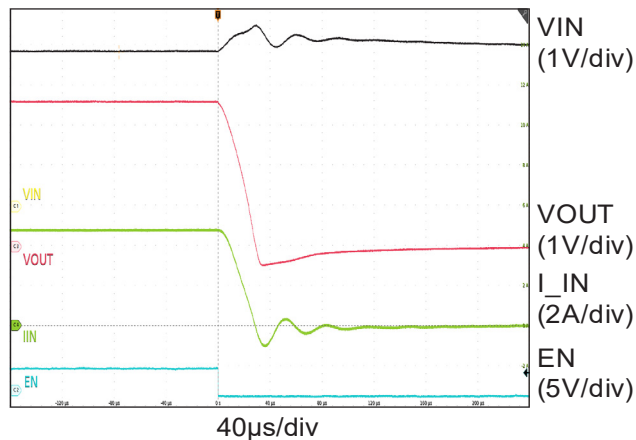

**Shut Down**  
( $V_{IN} = 28\text{ V}$ ,  $R_{OUT} = 4\text{ }\Omega$ )

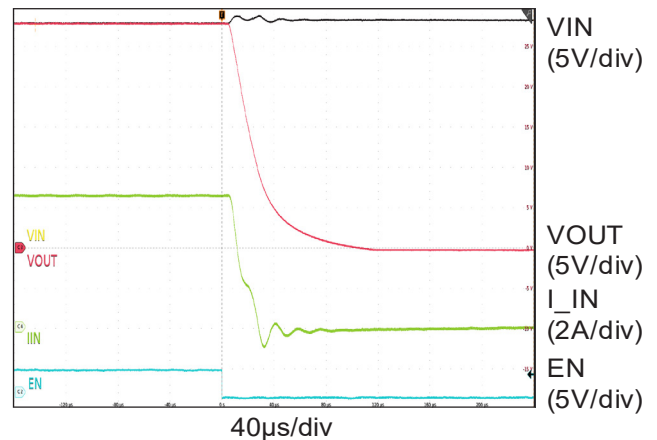

### Typical Characteristics

$T_A = 25\text{ }^\circ\text{C}$ ,  $V_{IN} = 28\text{ V}$ ,  $E_N = 5\text{ V}$ ,  $C_{IN} = 10\text{ }\mu\text{F}$ ,  $C_{OUT} = 10\text{ }\mu\text{F}$ ,  $C_{SS} = 5.6\text{ nF}$ ,  $C_{CAP} = 1\text{ nF}$ ,  $POVP=1\text{V}$ , unless otherwise specified.

**Ideal Diode True Reverse Current Blocking**  
( $V_{IN} = 28\text{ V}$ ,  $R_{OUT} = 5.6\text{ }\Omega$ )

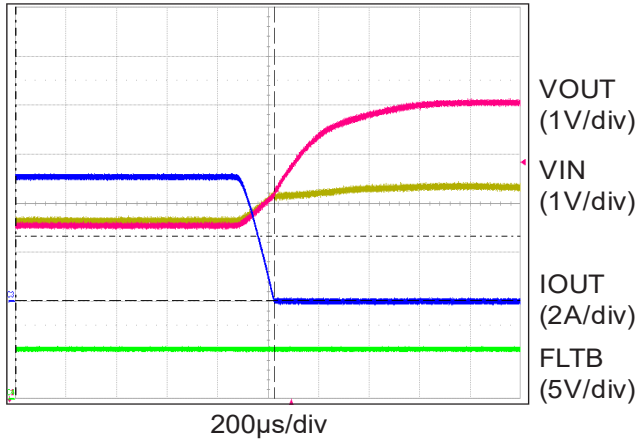

**Recovery Ideal Diode True Reverse Current Blocking**  
( $V_{IN} = 28\text{ V}$ ,  $R_{OUT} = 5.6\text{ }\Omega$ )

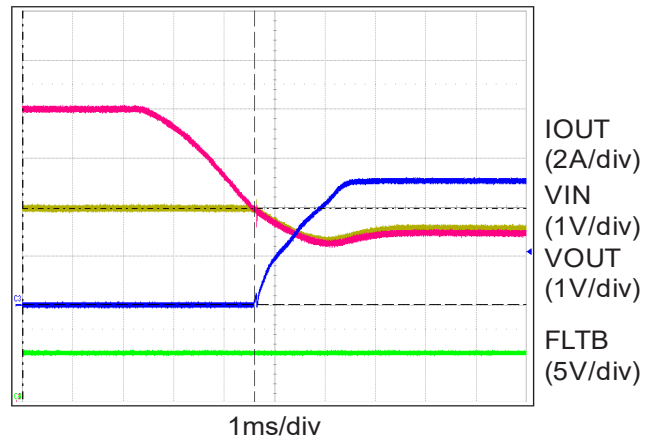

### Over Voltage Protection

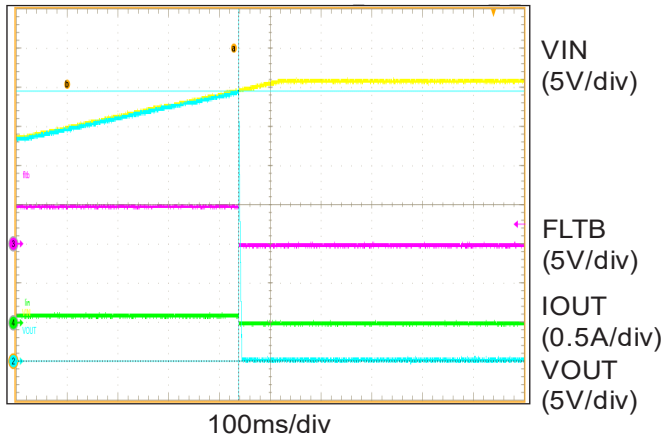

## Typical Characteristics

$T_A = 25\text{ }^\circ\text{C}$ , unless otherwise specified.

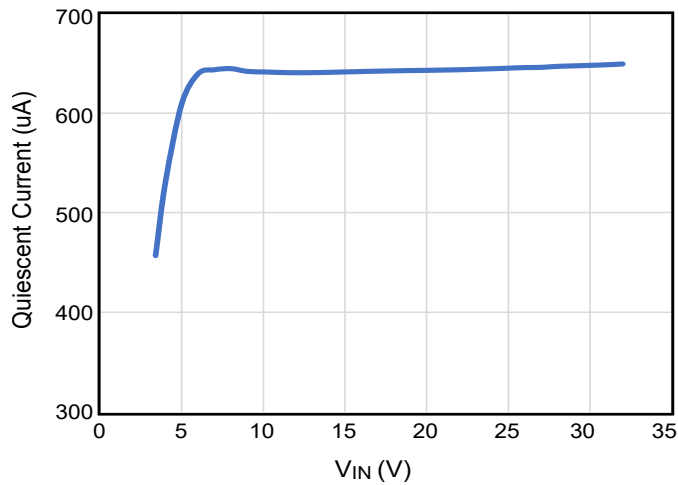

Figure 3. Quiescent Current vs. VIN

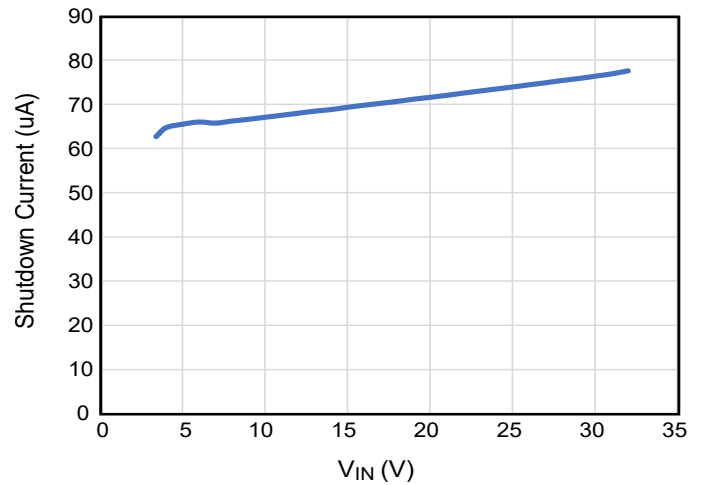

Figure 4. Shutdown Current vs. VIN

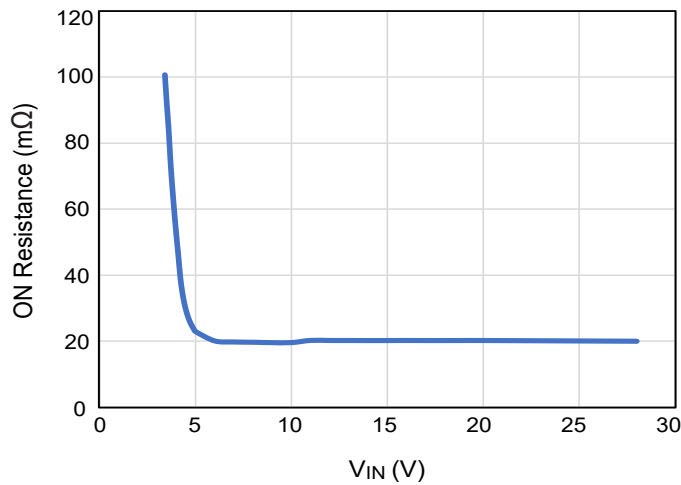

Figure 5. On Resistance vs. VIN

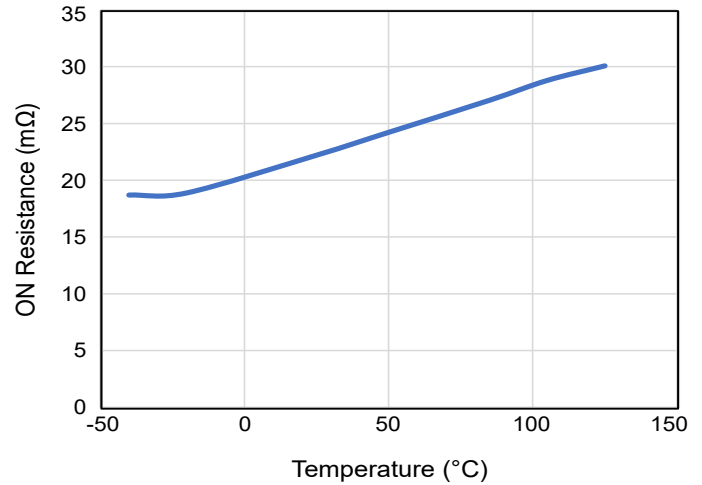

Figure 6. On Resistance vs. Temperature  
(VIN = 20 V)

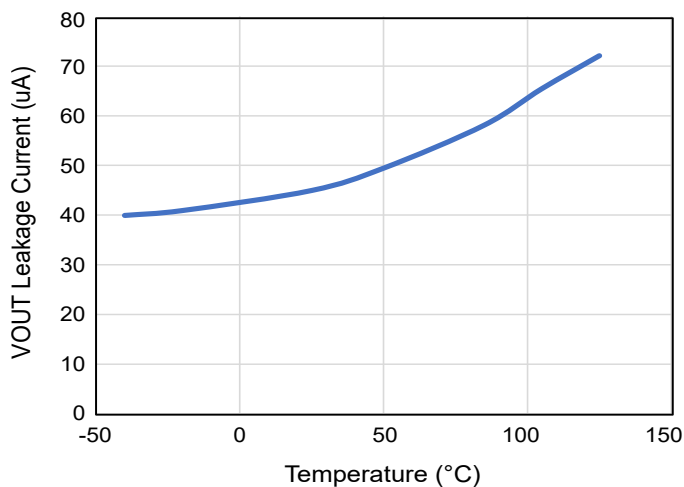

Figure 7. V<sub>OUT</sub> Leakage Current vs. Temperature

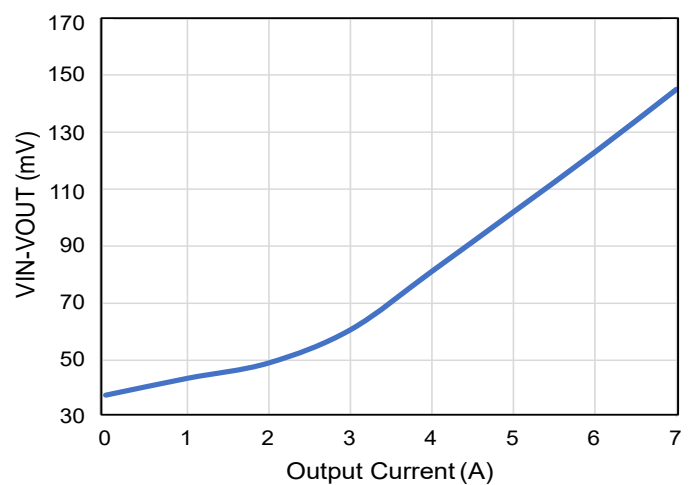

Figure 8. Ideal Diode Regulation Voltage vs. I<sub>OUT</sub>



## Detailed Description

The AOZ13937DI is a high-side protection switch with programmable soft-start, programmable over-voltage, over-temperature, and reverse current protections. It is capable of operating from 3.4 V to 32 V.

The internal power switch consists of back-to-back connected MOSFET. When the switch is enabled, the overall resistance between VIN and VOUT is only 20 mΩ, minimizing power loss and heat generation. The back-to-back configuration of MOSFET completely isolates VIN and VOUT when the switch is turned off, preventing leakage between the two pins.

### Power Delivery Capability

During start-up, the voltage at VOUT linearly ramps up to the VIN voltage over a period of time set by the soft-start time. This ramp time is referred to as the soft-start time and is typically in milliseconds. Figure 9 illustrates the soft-start condition and power dissipation.

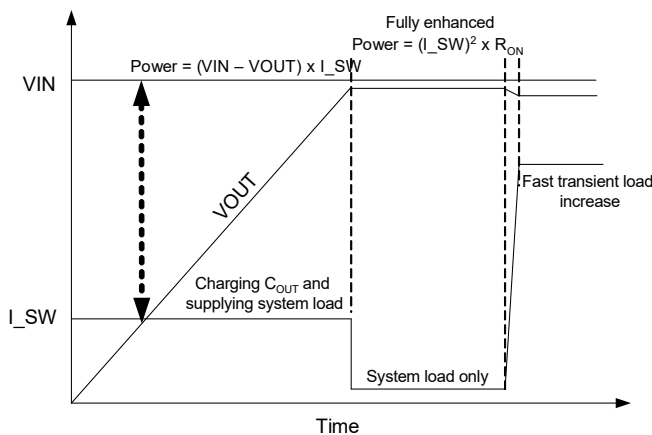

Figure 9. Soft-Start Power Dissipation

During this soft-start time, there will be a large voltage across the power switch. Also, there will be current I\_SW through the switch to charge the output capacitance. In addition, there may be load current to the downstream system as well. This total current is calculated as:

$$I_{SW} = C_{OUT} \left( \frac{dV_{OUT}}{dt} \right) + I_{SYS}$$

In the soft-start condition, the switch is operating in the linear mode, and power dissipation is high. The ability to handle this power is largely a function of the power MOSFET linear mode SOA and good package thermal performance Rθ<sub>JC</sub> (Junction-to-Case) as the soft-start ramp time is in milliseconds. Rθ<sub>JA</sub> (Junction-to-Ambient), which is more a function of PCB thermal performance, doesn't play a role.

With a high-reliability MOSFET as the power switch and superior packaging technology, the AOZ13937DI is capable of dissipating this power. The power dissipated is:

$$Power\ Dissipation = I_{SW} \times (VIN - VOUT)$$

To calculate the average power dissipation during the soft-start period: ½ of the input voltage should be used as the output voltage will ramp towards the input voltage, as shown in Figure 9.

For example, if the output capacitance C<sub>OUT</sub> is 10 μF, the input voltage VIN is 20 V, the soft-start time is 2 ms, and there is an additional 1 A of system current (I<sub>SYS</sub>), then the average power being dissipated by the part is:

$$I_{SW} = 10\mu F \left( \frac{20V}{2ms} \right) + 1A = 1.1A$$

$$Average\ Power\ Dissipation = 1.1A \times \frac{20V}{2} = 11W$$

Referring to the SOA curve in Figure 10, the maximum power allowed for 2 ms is 100W (5A x 20V or 10A x 10V). The AOZ13937DI power switch is robust enough to drive a large output capacitance with load in reasonable soft-start time.

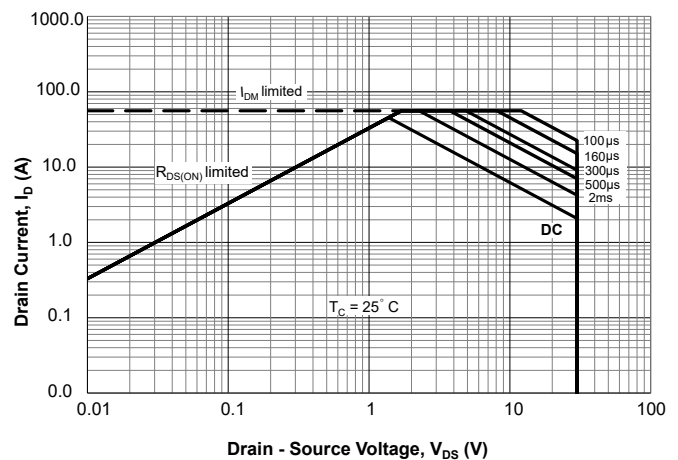

Figure 10. Safe Operating Area (SOA) Curves for Power Switch

After soft-start is completed, the power switch is fully on, and it is at its lowest resistance. The power switch acts as a resistor. Under this condition, the power dissipation is much lower than the soft-start period. However, as this is a continuous current, a low on-resistance is required to minimize power dissipation. Attention must be paid to board layout so that losses dissipated in the switch are dissipated to the PCB and hence the ambient.

With a low on-resistance of 20 mΩ, the AOZ13937DI provides the most efficient power delivery without much resistive power dissipation.

While Type C Extended Power Range (EPR) power delivery is limited to 28 V @ 5 A or a 140 W, many high-end laptops require peak currents far in excess of the 5 A. While the thermal design current (TDC) for a CPU may be low, peak current (IC<sub>Cmax</sub> in the case of Intel and EDP in the case of AMD) of many systems is often 2 x thermal design current. These events are typical of short duration (< 2 ms) and low duty cycle, but they are important for system performance as a CPU/GPU capable of operating at several GHz can boost its compute power in those 2 ms peak current events. The AOZ13937DI can handle such short, high current, transient pulses without any reliability degradation, thus enhancing the performance of high-end systems when plugged into the Type C adaptor. The shorter the pulse and the lower the duty cycle, the higher the pulse current that the part can sustain. The part has enough time to dissipate the heat generated from the pulse current with longer off-time, as shown in Figure 11. For example, AOZ13937DI can maintain 20A for 10 ms with a duty cycle of 2%.

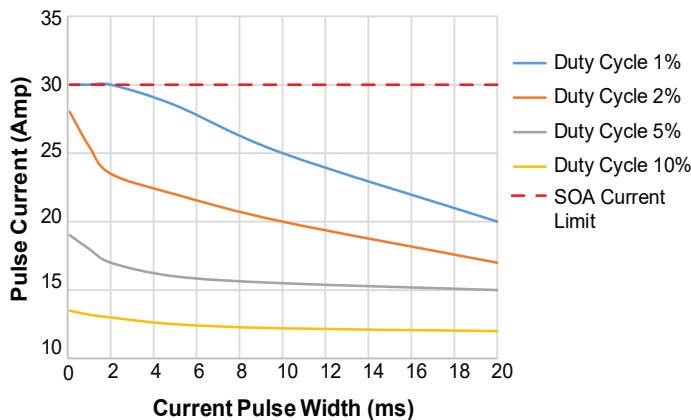

Figure 11. AOZ13937DI Power Switch Pulsed Current vs. Duration for a Given Duty Cycle

### Enable

The active high EN pin is the ON/OFF control for the power switch. The device is enabled when the EN pin is high and device is not in UVLO state. The EN pin must be driven to a logic high ( $>V_{EN\_H}$ ) or logic low ( $<V_{EN\_L}$ ) state to guarantee operation. AOZ13937DI draws about 75 μA supply current when it is disabled.

### Input Under-Voltage Lockout (UVLO)

The internal control circuit is powered from VIN. The under-voltage lockout (UVLO) circuit monitors the voltage at the input pin (VIN) and only allows the power switches to turn on when it is higher than 3.35V ( $V_{UVLO}$ ).

### Over-Voltage Protection (OVP)

The voltages at VIN pin are constantly monitored once the device is enabled. The OVP threshold can be programmed by either using an external resistor from POVP pin to GND or applying a DC voltage to POVP pin. When EN > 1.4 V and before the soft start begins, the threshold setting at POVP will be latched and any subsequent changes will not affect the OVP threshold. The POVP voltage setting is listed in Table 1.

Table 1. Over-Voltage Protection Threshold Setting

POVP Voltage	OVP Threshold (Min)
POVP < 1.25 V	33 V
POVP > 1.4 V	23 V

In case the voltage exceeds the OVP threshold, over-voltage protection is activated:

1. If the power switch is on, it will be turned off after OVP debounce time ( $t_{OVP\_DEB}$ ) to isolate VOUT from VIN
2. OVP will prevent power switch to be turned on if it is in off state

In either case, FLTB pin is pulled low to report the fault condition.

### Ideal Diode True Reverse Current Blocking (IDTRCB)

When the device is ON with no load or under light load conditions, it regulates VOUT to be 35 mV below VIN. As the load current is increasing or decreasing, the device adjusts the gate drive to maintain the 35 mV drop from VIN to VOUT. As the load current continues to increase the device increases the gate drive until the gate is fully turned on and VIN to VOUT drop is determined by IR drop through the MOSFET. If for any reason VOUT increases such that VIN to VOUT drop to less than 35 mV, the gate driver forces the switch to turn off.

### Thermal Shutdown Protection (TSD)

Thermal shutdown protects device from excessive temperature. When the die temperature reaches 140 °C, the power switch is turned off. There is a 30 °C hysteresis for the AOZ13937DI-01 only: The power switch is allowed to turn on again if the die temperature drops below approximately 110 °C.

**AOZ13937DI-01(Auto-Restart version):** Once TSD is removed, the power switch will be turn on again with soft start.

**AOZ13937DI-02(Latch-Off version):** The device will latch off and can only turn on by either toggling EN pin or cycling the input power supply.

### Soft-Start Slew-Rate Control

When EN pin is asserted high, the slew rate control applies voltage on the gate of the power switch in a manner such that the output voltage is ramped up linearly until VOUT reaches VIN voltage level. The output ramps up time ( $t_{ON}$ ) is programmable by an external soft-start capacitor ( $C_{SS}$ ). The following formula provides the estimated 10% to 90% ramp up time.

$$t_{ON} = \frac{C_{SS}}{2}$$

where  $C_{SS}$  is in nF and  $t_{ON}$  is in ms

### System Startup

The device is enabled when  $EN \geq 1.4$  V and VIN is higher than UVLO threshold ( $V_{UVLO}$ ). The device will check if any fault condition exists. If no fault exists, the power switch is turned on and VOUT is then ramped up after enable delay ( $t_{D\_ON}$ ), controlled by the soft-start time ( $t_{ON}$ ) until VOUT reaches VIN voltage level. Soft start time can be programmed externally through SS input with a capacitor  $C_{SS}$  to control in-rush current.

### In-rush Current Limit and SCP at Start Up

AOZ13937DI has the current limit and short circuit protection functions at start up. The current limit is a function of voltage drop from VIN to VOUT. The limit increases if the (VIN – VOUT) voltage decreases. With this current limit control, the inrush current can be effectively clamped to reduce the initial current spikes. At initial startup, the internal power switch carries large voltage close to VIN and has large power loss. To ensure the internal FET working in Safe Operation Area (SOA), a fixed timer is set to shut down the power switch if the inrush current is clamped by current limit ramp for about 500  $\mu$ s continuously. This timer will be reset once the inrush current drops below the current limit. For short circuit event, the part will shut down after this 500  $\mu$ s timer is finished. In case of large output capacitors, the soft start time needs to increase to avoid the large inrush current hitting the current limit for 500  $\mu$ s. Both current limit and SCP shutdown functions are disabled after switch is fully turned on.

**AOZ13937DI-01 (Auto-Restart version):** The power switch is turned off under short circuit condition at startup. The device will try to restart indefinitely for every 64ms( $t_{SCP\_REC\_01}$ ) until it is disabled.

**AOZ13937DI-02 (Latch-Off version):** The power switch turned off under short circuit condition at startup. The device will try to start up for 4 times with interval of 2ms( $t_{SCP\_REC\_02}$ ). If short circuit condition still exist after these 4 times retry, the device will be latched off.

### Fault Protection

The AOZ13937DI offers multiple protection against the following fault conditions: VIN over-voltage (OVLO), Reverse Current Blocking when VOUT > VIN, and over temperature.

When the device is first enabled, the power switch is off and fault conditions are checked. If any of these conditions exist:

1. VIN is higher than the OVP threshold ( $V_{OVLO}$ )
2. Die temperature is higher than thermal shutdown threshold ( $T_{SD}$ )
3. VOUT is higher than VIN

The power switch will not be turned on and FLTB pin will be pulled low for OVP and TSD conditions to indicate fault status of the device.

The power switch will be turned on once TRCB condition no longer exists. The device will continuously monitor these fault conditions. In addition, the short circuit condition is being monitored during the soft start. See previous section on SCP at start up for more details. Table 2 and 3 summarize the fault response and FLTB flag status to all protection functions for AOZ13937DI-01 and AOZ13937DI-02, respectively.

**Table 2. AOZ13937DI-01 Fault Flag Response to all Protection Functions**

Protection	Fault Response	FLTB Status
IDTRCB	Auto-restart without soft-start at fault removal	High Impedance
Startup SCP	Auto-restart after 64ms	Low
TSD	Auto-restart with soft-start at fault removal	Low
OVP	Auto-restart with soft-start at fault removal	Low

**Table 3. AOZ13937DI-02 Fault Flag Response to all Protection Functions**

Protection	Fault Response	FLTB Status
IDTRCB	Auto-restart without soft-start at fault removal	High Impedance
Startup SCP	4 times retry then latch-off	Low
TSD	Latch-off	Low
OVP	Latch-off	Low

### Input Capacitor Selection

The input capacitor prevents large voltage transients from appearing at the input, and provides the instantaneous current needed each time the switch turns on to charge output capacitors and to limit input voltage drop. It also

prevents high-frequency noise on the power line from passing through to the output. The input capacitor should be located as close to the pin as possible. A 10  $\mu\text{F}$  ceramic capacitor is recommended. The USB specification limits the capacitance on VBUS to a maximum of 10  $\mu\text{F}$ . Use this maximum value for noise immunity due to the system and cable plug/unplug transients.

### Power Dissipation Calculation

The following equation can be used to estimate the power dissipation for normal load condition:

$$\text{Power Dissipated} = R_{ON} \times (I_{OUT})^2$$

### Soft Start and Output Capacitor Selection Guideline

The output capacitor has to supply enough current for a large peak current load that it may encounter during system transient. This bulk capacitance must be large enough to supply fast transient load current in order to prevent the output from dropping.

The external soft start capacitor ( $C_{SS}$ ) to determine soft start time ( $t_{ON}$ ) should be selected properly with output capacitor and system resistive load current conditions in the application. Figure 12 shows the recommended  $C_{SS}$  range with output capacitor values under various resistive load current conditions.

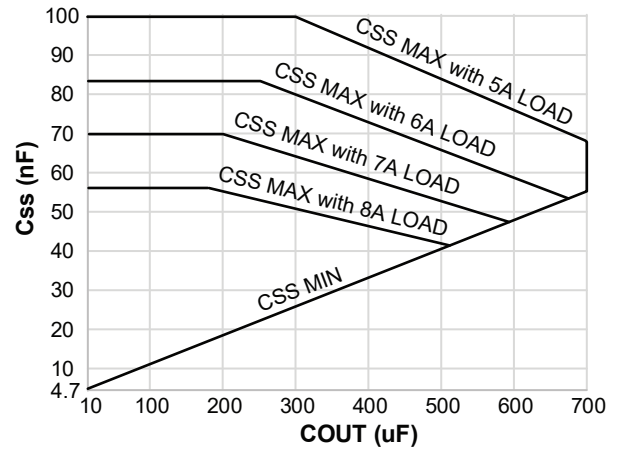
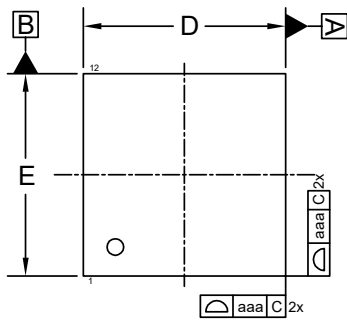

Figure 12. Recommended Soft Start Capacitor vs. Output Capacitor for Various Resistive Load Current

If the  $C_{SS}$  is below  $C_{SS\_min}$  line in the Figure 12, the inrush current reaches internal current limit for more than 500us and power switch is turned off to prevent the power MOSFET from violating MOSFET SOA.  $V_{OUT}$  cannot ramp up due to the current limit protection during start up and larger  $C_{SS}$  is required for successful startup. If the  $C_{SS}$  is above the load current lines in the Figure 12, the soft start time is too long so that the energy during the soft start time is large enough to damage the power MOSFET.

Package Dimensions, DFN3x3-12L



TOP VIEW

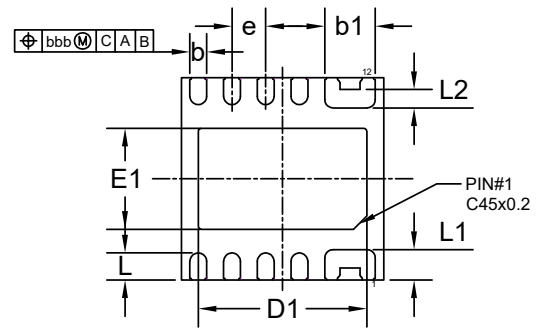

BOTTOM VIEW

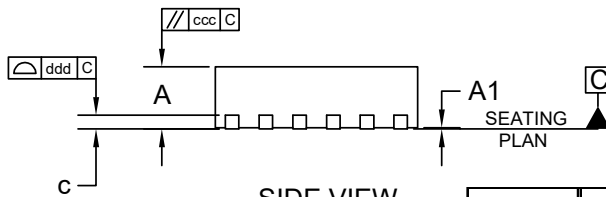

SIDE VIEW

RECOMMENDED LAND PATTERN

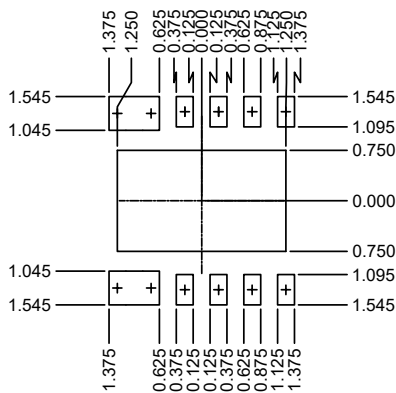

UNIT: mm

SYMBOLS	DIMENSION IN MM			DIMENSION IN INCHES		
	MIN	NOM	MAX	MIN	NOM	MAX
A	0.800	0.900	1.000	0.031	0.035	0.039
A1	0.000	0.020	0.050	0.000	0.001	0.002
b	0.200	0.250	0.300	0.008	0.010	0.012
b1	0.700	0.750	0.800	0.028	0.030	0.031
c	0.195	0.203	0.211	0.008	0.008	0.008
D	2.900	3.000	3.100	0.114	0.118	0.122
D1	2.400	2.500	2.600	0.094	0.098	0.102
E	2.900	3.000	3.100	0.114	0.118	0.122
E1	1.400	1.500	1.600	0.055	0.059	0.063
e	0.500 BSC			0.020 BSC		
L	0.300	0.400	0.500	0.012	0.016	0.020
L1	0.350	0.450	0.550	0.014	0.018	0.022
L2	0.220	0.270	0.320	0.009	0.011	0.013
aaa	0.150			0.006		
bbb	0.100			0.004		
ccc	0.100			0.004		
ddd	0.080			0.003		

NOTE:

1. DIMENSIONING AND TOLERANCING CONFORM TO ASME Y14.5M-1994.
2. CONTROLLING DIMENSION IS MILLIMETER.  
CONVERTED INCH DIMENSIONS ARE NOT NECESSARILY EXACT.
3. DIMENSION b APPLIES TO METALLIZED TERMINAL AND IS MEASURED BETWEEN 0.15mm. AND 0.30mm FROM THE TERMINAL TIP. IF THE TERMINAL HAS THE OPTIONAL RADIUS ON THE OTHER END OF THE TERMINAL, THE DIMENSION b SHOULD NOT BE MEASURED IN THAT RADIUS AREA.
4. COPLANARITY ddd APPLIES TO THE TERMINALS AND ALL OTHER BOTTOM SURFACE METALLIZATION.

**Tape and Reel Dimensions, DFN3x3-12L**

**DFN3x3 EP Carrier Tape**

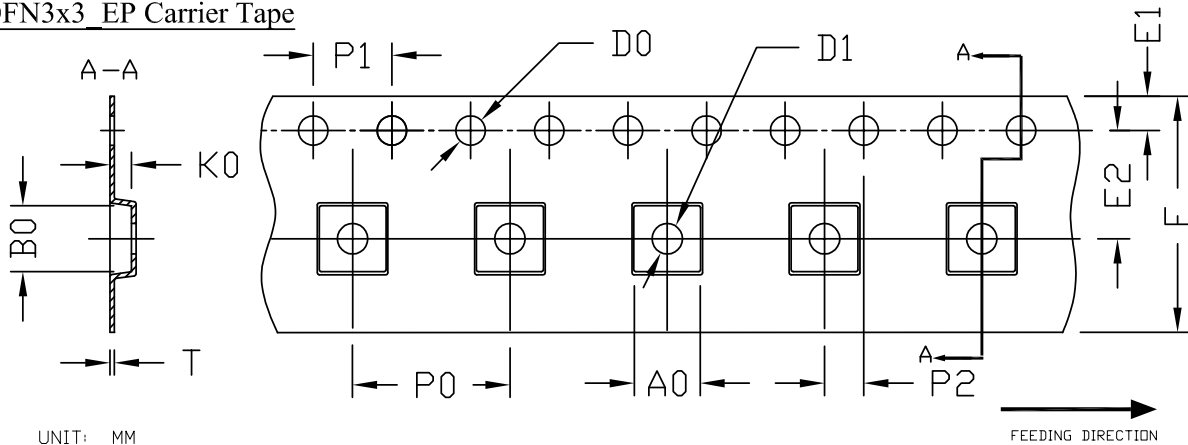

UNIT: MM

PACKAGE	A0	B0	K0	D0	D1	E	E1	E2	P0	P1	P2	T
DFN3x3_EP	3.40 ±0.10	3.35 ±0.10	1.10 ±0.10	1.50 +0.10 -0	1.50 +0.10 -0	12.00 ±0.30	1.75 ±0.10	5.50 ±0.05	8.00 ±0.10	4.00 ±0.10	2.00 ±0.05	0.30 ±0.05

**DFN3x3 EP REEL**

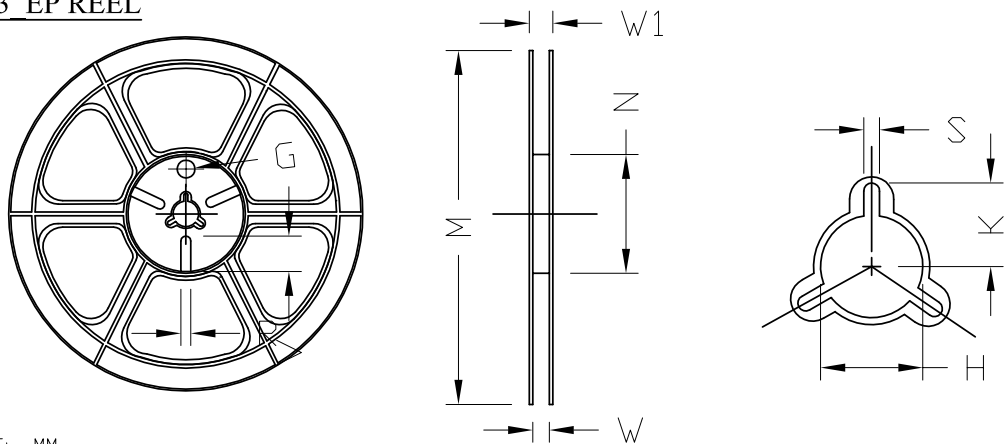

UNIT: MM

TAPE SIZE	REEL SIZE	M	N	W	W1	H	K	S	G	R	V
12 mm	ø330	ø330.00 ±0.50	ø97.00 ±0.10	13.00 ±0.30	17.40 ±1.00	ø13.00 +0.50 -0.20	10.60	2.00 ±0.50	---	---	---

**DFN3x3 EP TAPE**

Leader / Trailer  
& Orientation

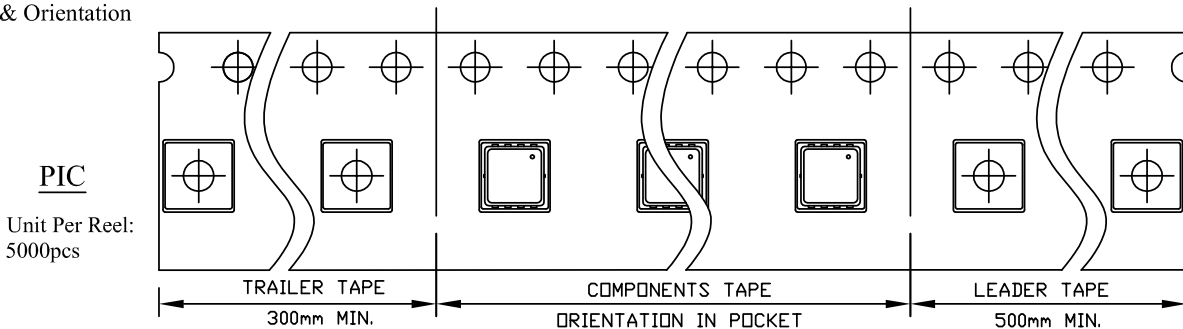

**Part Marking**

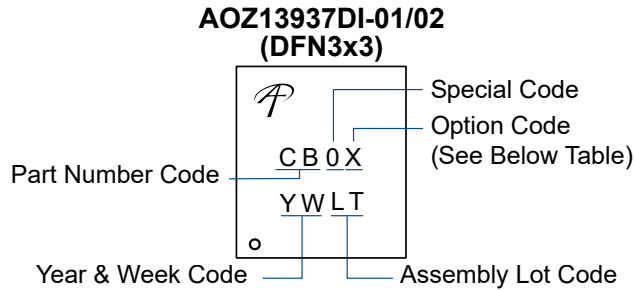

Part Number	Fault Recovery	Code
AOZ13937DI-01	Auto-Restart	CB01
AOZ13937DI-02	Latch-Off	CB02

**LEGAL DISCLAIMER**

Applications or uses as critical components in life support devices or systems are not authorized. Alpha and Omega Semiconductor does not assume any liability arising out of such applications or uses of its products. AOS reserves the right to make changes to product specifications without notice. It is the responsibility of the customer to evaluate suitability of the product for their intended application. Customer shall comply with applicable legal requirements, including all applicable export control rules, regulations and limitations.

AOS's products are provided subject to AOS's terms and conditions of sale which are set forth at:  
[http://www.aosmd.com/terms\\_and\\_conditions\\_of\\_sale](http://www.aosmd.com/terms_and_conditions_of_sale)

**LIFE SUPPORT POLICY**

ALPHA AND OMEGA SEMICONDUCTOR PRODUCTS ARE NOT AUTHORIZED FOR USE AS CRITICAL COMPONENTS IN LIFE SUPPORT DEVICES OR SYSTEMS.

As used herein:

1. Life support devices or systems are devices or systems which, (a) are intended for surgical implant into the body or (b) support or sustain life, and (c) whose failure to perform when properly used in accordance with instructions for use provided in the labeling, can be reasonably expected to result in a significant injury of the user.
2. A critical component in any component of a life support, device, or system whose failure to perform can be reasonably expected to cause the failure of the life support device or system, or to affect its safety or effectiveness.