

AlphaZBL™ AC-DC Active Bridge Rectifier

- Complete AC-DC power supplies for high efficiency requirements: adaptors, PC, AIO, servers, telecom
- Replaces traditional bridge rectifiers to enhance efficiency and reduce power consumption
- Self-powered V_{CC} in AC system with ultra-low quiescent current
- Integrated 190m Ω , 600V N-channel MOSFET (AOZ7270DI)
- A low reverse threshold of 1mV for improved efficiency
- Low quiescent current 5 μ A

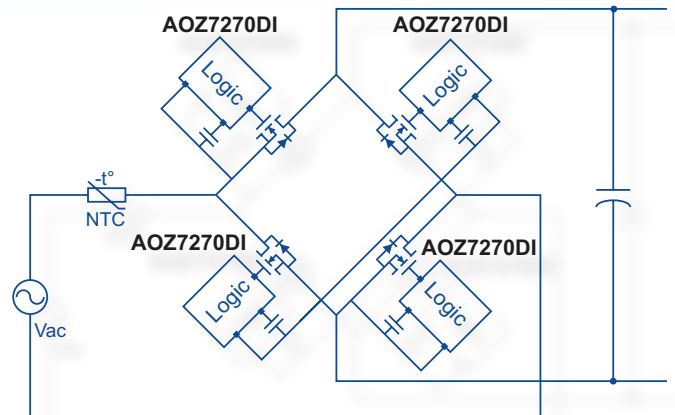

APPLICATIONS

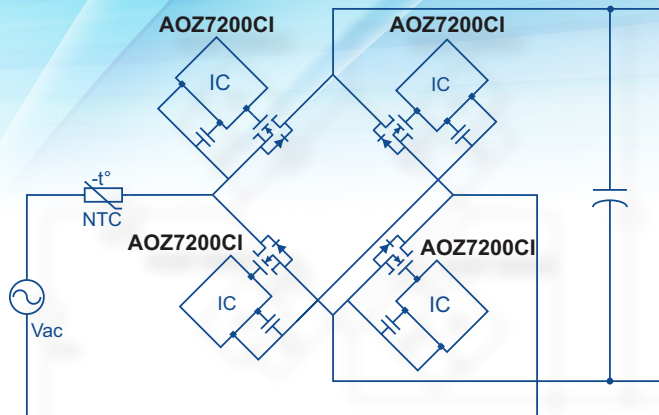

Part Number	Package	MOSFET BVD _{SS} (V)	R _{DS(ON)} (mΩ)	V _{CC} (V)	ESD Rating (kV)	Operating Temp. (°C)
AOZ7200CI	SOT23-5	N/A	N/A	12.9 - 15.2	2	-40 to 125
AOZ7270DI	DFN5x7	600	190	12.9 - 15.2	2	-40 to 125

FEATURES AND ADVANTAGES

AOS Active Bridge Rectifier AlphaZBL™

Standalone Driver

> AOZ7200CI

- Drives all external N-MOSFETs directly
- Replaces a power diode in HV bridge rectifier
- Self-powered in AC system
- Low reverse threshold 1mV
- Low quiescent current 5μA
- Very low external part count
- Avoid Hi/Low side MOSFET short-through prevention
- V_{CC} UVLO for High/Low-side controllers
- SOT23 package

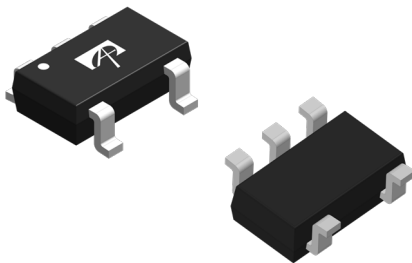

Integrated Solution

> AOZ7270DI

- Replaces a power diode in HV bridge rectifier
- Self-powered in AC system
- Internal 0.19Ω 600V N-channel MOSFET
- Low reverse threshold 1mV
- Low quiescent current 5μA
- Thermally enhanced
- Very low external part count
- Avoid Hi/Low side MOSFET short-through prevention
- V_{CC} UVLO for High/Low-side converters
- DFN5x7 package

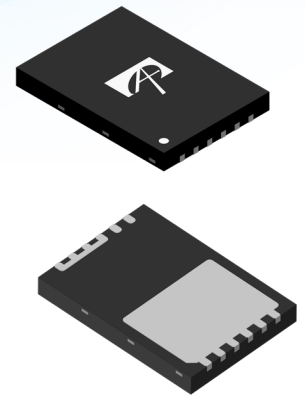

AOS SALES OFFICES

UNITED STATES

475 Oakmead Pkwy
Sunnyvale, CA 94085
Phone: +1 (408) 830-9742
Email: Inquiries@aosmd.com

EUROPE

Phone: +49 7131 6446756
Email: AOSEurope@aosmd.com

JAPAN

5F, Yurakucho Building
1-10-1 Yurakucho
Chiyoda-ku
Tokyo 102-0083
Phone: +81 (3) 6826-1401
Email: AOSJapan@aosmd.com

To contact any of our sales partners
worldwide, please visit our website at:
www.aosmd.com/contact

SOUTH KOREA

10th Floor, Bandi Building
Bongeunsa-ro 114
Gangnam-gu
Seoul 135-907
Phone: +82 (2) 557-8501
Email: AOSKorea@aosmd.com

TAIWAN

9/F, No. 292 Yangguang Street
Neihu District
Taipei City 11491
Phone: +886 (2) 8751-5616
Email: AOSTaiwan@aosmd.com

HONG KONG

Room 701, Tesbury Center
28 Queen's Road East
Wanchai
Phone: +86 (755) 8351-7733
Email: AOSChina@aosmd.com

CHINA

SHENZHEN

East 8/F, Matsunichi Building
#9996 Shennan Blvd.
Shenzhen 518057
Phone: +86 (755) 8351-7733
Email: AOSChina@aosmd.com

SHANGHAI

Room 1002-1005, Tower 1
Kerry EverBright City
218 Tianmu West Road
Shanghai 200070
Phone: +86 (21) 6353-3218
Email: AOSChina@aosmd.com

Alpha and Omega Semiconductor Limited, or AOS, is a designer, developer and global supplier of a broad range of power semiconductor products. AOS' products are aimed at, but not limited to applications such as portable computers, flat panel TVs, LED lighting, smart phones, battery backs, consumer and industrial motor controls, automotive electronics, and power supplies for TVs, computers, servers and telecommunication equipment.