

Package Dimensions, QFN 4x4B, 23 Lead EP2_S

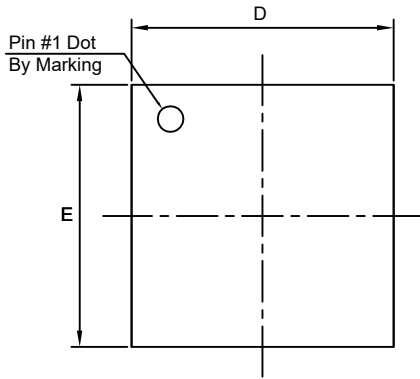

TOP VIEW

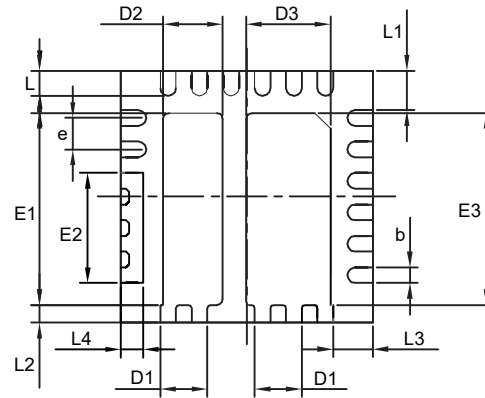

BOTTOM VIEW

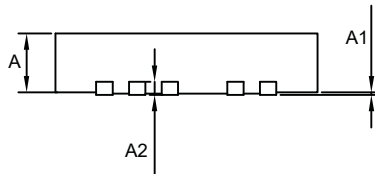

SIDE VIEW

RECOMMENDED LAND PATTERN

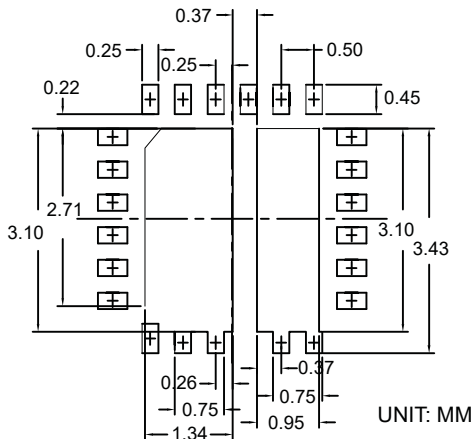

Dimensions in millimeters

Symbols	Min.	Typ.	Max.
A	0.80	0.90	1.00
A1	0.00	—	0.05
A2	0.2 REF		
E	3.90	4.00	4.10
E1	2.95	3.05	3.15
E2	1.65	1.75	1.85
E3	2.95	3.05	3.15
D	3.90	4.00	4.10
D1	0.65	0.75	0.85
D2	0.85	0.95	1.05
D3	1.24	1.34	1.44
L	0.35	0.40	0.45
L1	0.57	0.62	0.67
L2	0.23	0.28	0.33
L3	0.57	0.62	0.67
L4	0.30	0.35	0.40
b	0.20	0.25	0.30
e	0.50 BSC		

Dimensions in inches

Symbols	Min.	Typ.	Max.
A	0.031	0.035	0.039
A1	0.000	—	0.002
A2	0.008 REF		
E	0.154	0.157	0.141
E1	0.116	0.120	0.124
E2	0.065	0.069	0.073
E3	0.116	0.120	0.124
D	0.154	0.157	0.141
D1	0.026	0.030	0.033
D2	0.033	0.037	0.041
D3	0.049	0.053	0.057
L	0.014	0.016	0.018
L1	0.022	0.024	0.026
L2	0.009	0.011	0.013
L3	0.022	0.024	0.026
L4	0.012	0.014	0.016
b	0.008	0.010	0.012
e	0.020 BSC		

Notes:

1. Controlling dimensions are in millimeters. Converted inch dimensions are not necessarily exact.
2. Tolerance: ± 0.05 unless otherwise specified.
3. Radius on all corners is 0.152 max., unless otherwise specified.
4. Package wrapage: 0.012 max.
5. No plastic flash allowed on the top and bottom lead surface.
6. Pad planarity: ± 0.102
7. Crack between plastic body and lead is not allowed.

Tape and Reel Dimensions, QFN 4x4, 23 Lead EP2_S

Carrier Tape

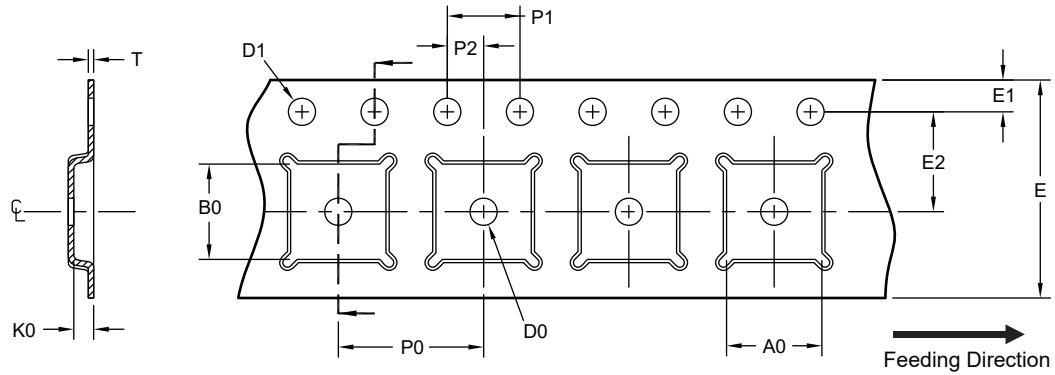

UNIT: mm

Package	A0	B0	K0	D0	D1	E	E1	E2	P0	P1	P2	T
QFN 4x4 (12mm)	4.35 ±0.10	4.35 ±0.10	1.10 ±0.10	1.50 Min.	1.50 +0.10/-0	12.00 ±0.30	1.75 ±0.10	5.50 ±0.05	8.00 ±0.10	4.00 ±0.10	2.00 ±0.05	0.30 ±0.05

Reel

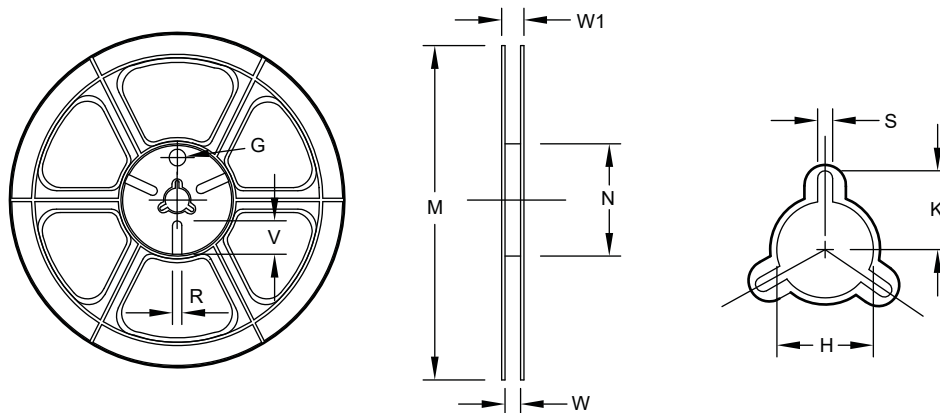

UNIT: mm

Tape Size	Reel Size	M	N	W	W1	H	K	S	G	R	V
12mm	ø330	ø330.0 ±2.0	ø79.0 ±1.0	12.4 +2.0/-0.0	17.0 +2.6/-1.2	ø13.0 ±0.5	10.5 ±0.2	2.0 ±0.5	—	—	—

Leader/Trailer and Orientation

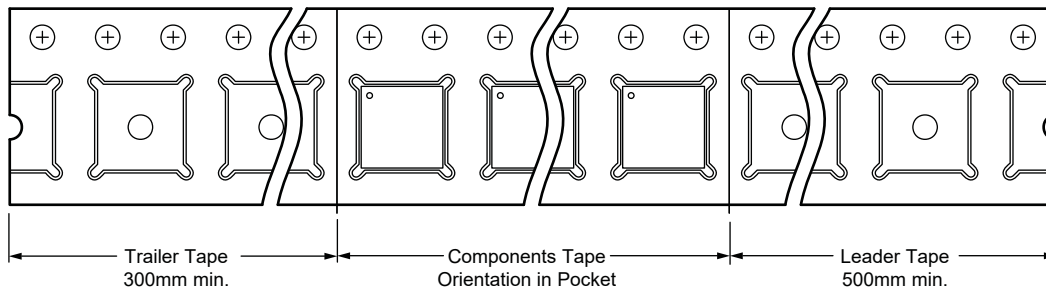

Part Marking

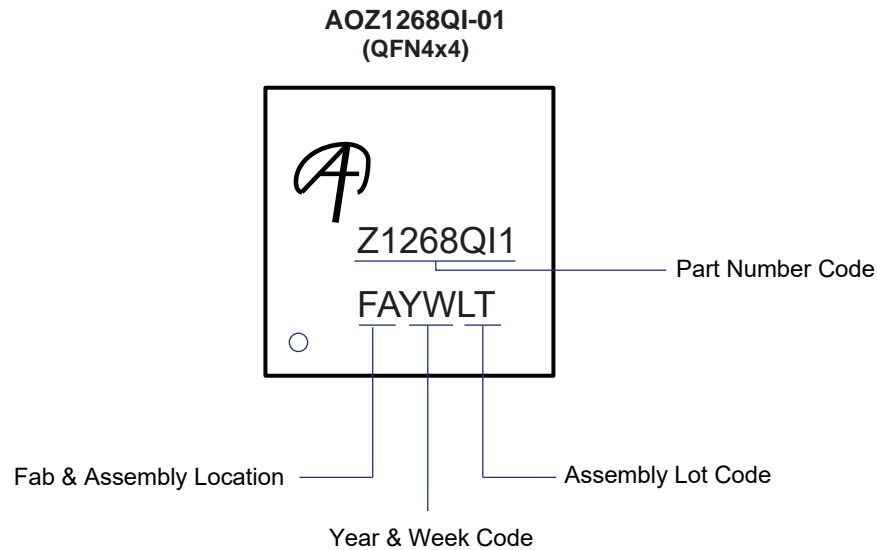

LEGAL DISCLAIMER

Applications or uses as critical components in life support devices or systems are not authorized. AOS does not assume any liability arising out of such applications or uses of its products. AOS reserves the right to make changes to product specifications without notice. It is the responsibility of the customer to evaluate suitability of the product for their intended application. Customer shall comply with applicable legal requirements, including all applicable export control rules, regulations and limitations.

AOS' products are provided subject to AOS' terms and conditions of sale which are set forth at:
http://www.aosmd.com/terms_and_conditions_of_sale

LIFE SUPPORT POLICY

ALPHA AND OMEGA SEMICONDUCTOR PRODUCTS ARE NOT AUTHORIZED FOR USE AS CRITICAL COMPONENTS IN LIFE SUPPORT DEVICES OR SYSTEMS.

As used herein:

- | | |
|---|---|
| <p>1. Life support devices or systems are devices or systems which, (a) are intended for surgical implant into the body or (b) support or sustain life, and (c) whose failure to perform when properly used in accordance with instructions for use provided in the labeling, can be reasonably expected to result in a significant injury of the user.</p> | <p>2. A critical component in any component of a life support, device, or system whose failure to perform can be reasonably expected to cause the failure of the life support device or system, or to affect its safety or effectiveness.</p> |
|---|---|