

General Description

The AOZ8S312BD4 is a transient voltage suppressor array designed to protect high speed data lines such as HDMI 1.4/2.0, USB 3.2, LVDS, and V-by-one from damaging ESD events.

This device incorporates a numbers of surge rated, low capacitance steering diodes and a TVS in a single package. During transient conditions, the steering diodes direct the transient to either the positive side of the power supply line or to ground.

The AOZ8S312BD4 provides a typical capacitance of 0.28 pF and low insertion loss providing greater signal integrity making it ideally suited for HDMI 1.4/2.0 or USB 3.2 applications, such as Digital TVs, DVD players, computing, set-top boxes and MDDI applications in mobile computing devices.

The AOZ8S312BD4 comes in a RoHS compliant and Halogen Free 2.5 mm x 1.0 mm x 0.55 mm DFN-10 package and is rated for -40°C to +125°C junction temperature range.

Features

- IEC 61000-4-2 (ESD):
 - Air discharge: ±15 kV
 - Contact discharge: ±15 kV
- IEC 61000-4-5 (Lightning, 8/20 μs) 5 A
- Human Body Model (HBM) ±8 kV
- Protects four I/O lines
- Low capacitance between I/O to GND: 0.28 pF
- Low clamping voltage
- Low operating voltage: 3.3 V, 5 V

Applications

- HDMI 1.4/2.0, USB 3.2, Thunderbolt, V-by-One
- Monitors and flat panel displays
- Set-top box
- Video graphics cards
- Notebook computers



Typical Applications

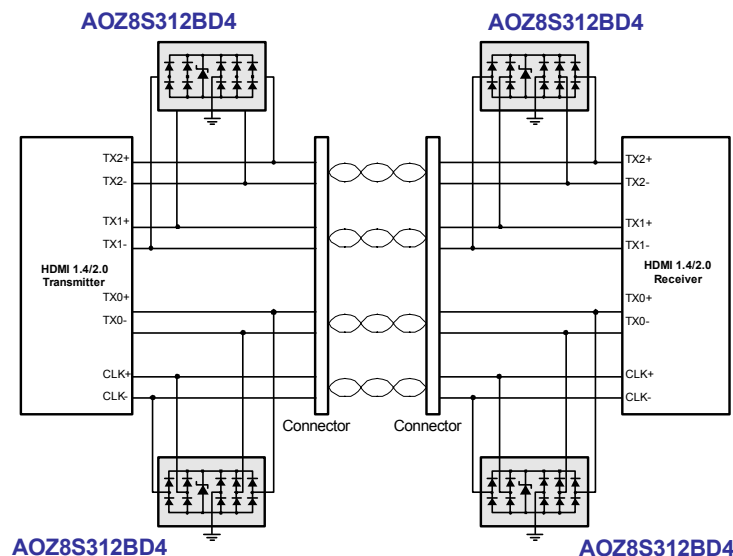

Ordering Information

Part Number	Ambient Temperature Range	Package	Environmental
AOZ8S312BD4-03	-40°C to +125°C	2.5 mm x 1.0 mm DFN-10	Green Product
AOZ8S312BD4-05	-40°C to +125°C	2.5 mm x 1.0 mm DFN-10	Green Product



AOS Green Products use reduced levels of Halogens, and are also RoHS compliant.

Please visit www.aosmd.com/media/AOSGreenPolicy.pdf for additional information.

Pin Configuration

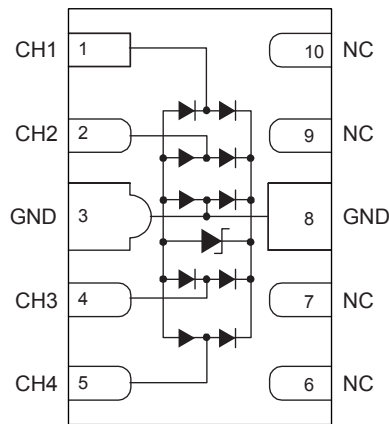

DFN-10
(Top View)

Absolute Maximum Ratings

Exceeding the Absolute Maximum ratings may damage the device.

Parameter	Rating
Storage Temperature (T_S)	-65 °C to +150 °C
ESD Rating per IEC 61000-4-2, contact ⁽¹⁾	±15 kV
ESD Rating per IEC 61000-4-2, air ⁽¹⁾	±15 kV
ESD Rating per Human Body Model ⁽²⁾	±8 kV

Notes:

- IEC 61000-4-2 discharge with $C_{Discharge} = 150\text{pF}$, $R_{Discharge} = 330\ \Omega$.
- Human Body Discharge per MIL-STD-883, Method 3015 $C_{Discharge} = 100\ \text{pF}$, $R_{Discharge} = 1.5\ \text{k}\Omega$.

Maximum Operating Ratings

Parameter	Rating
Junction Temperature (T_J)	-40 °C to +125 °C

Electrical Characteristics

T_A = 25°C unless otherwise specified. Any I/O Pin-to-Ground.

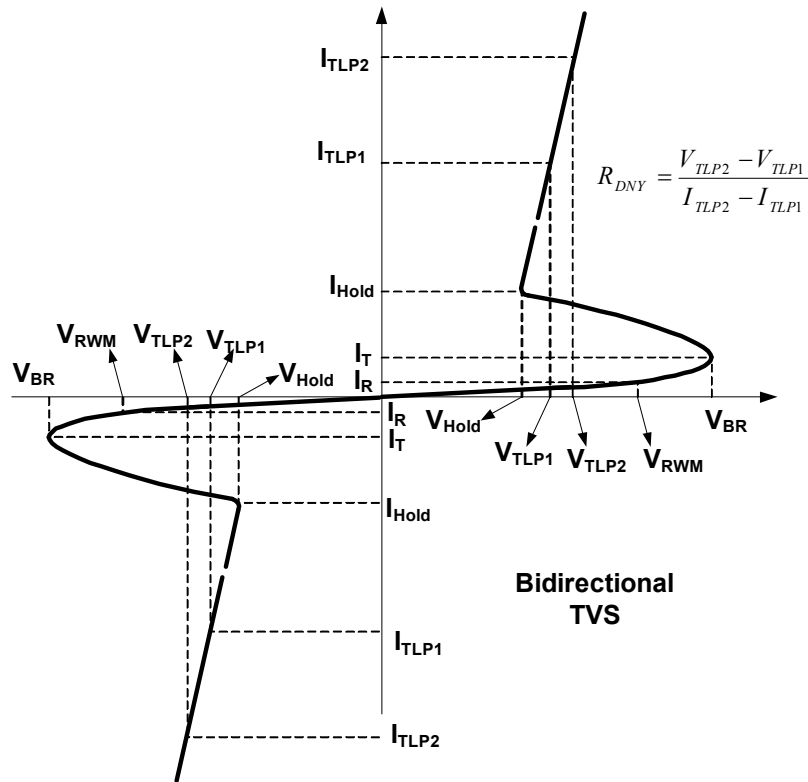

Symbol	Parameter	Conditions	Min.	Typ.	Max	Units
V _{RWM}	Reverse Working Voltage	AOZ8S312BD4-03			3.3	V
		AOZ8S312BD4-05			5	V
V _{BR}	Reverse Breakdown Voltage	I _T = 100 μA	6		9	V
I _R	Reverse Leakage Current	Max. V _{RWM}		1	100	nA
V _{CL}	Clamping Voltage ⁽³⁾⁽⁴⁾ (100 ns Transmission Line Pulse, I/O Pin to GND)	I _{TLP} = 1 A		2.5		V
		I _{TLP} = -1 A		-2.5		V
R _{DNY}	Dynamic Resistance ⁽³⁾	I _{TLP} = 16 A		6		V
		I _{TLP} = -16 A		-6		V
C _J	Junction Capacitance	V _{PIN 3,8} = 0 V, V _{I/O} = 1.65 V, f = 1 MHz		0.28	0.34	pF
		V _{PIN 3,8} = 0 V, V _{I/O} = 1.65 V, f = 1 MHz, I/O Pin-to-I/O Pin ⁽³⁾		0.28		pF

Notes:

- 3. These specifications are guaranteed by design and characterization.
- 4. Measurements performed using a 100ns Transmission Line Pulse (TLP) system.

Typical Characteristics

Positive Transmission Line Pulse
($T_P=100\text{ns}$, $T_R=0.2\text{ns}$)

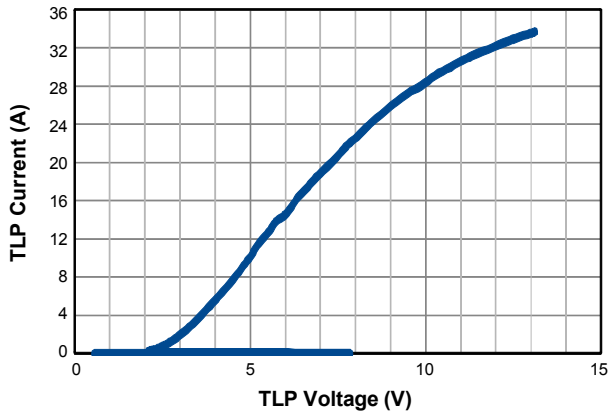

Negative Transmission Line Pulse
($T_P=100\text{ns}$, $T_R=0.2\text{ns}$)

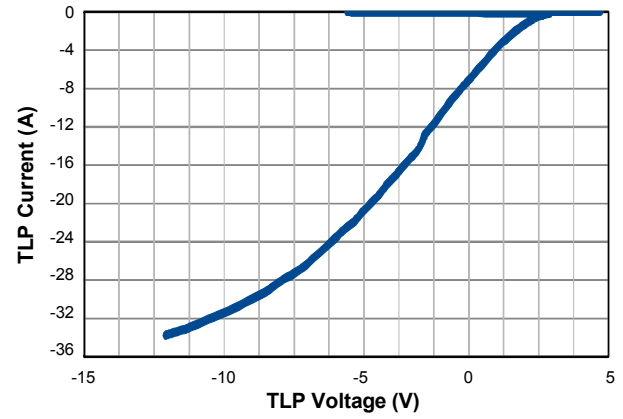

Typical Variations of CJ vs. Input Voltage

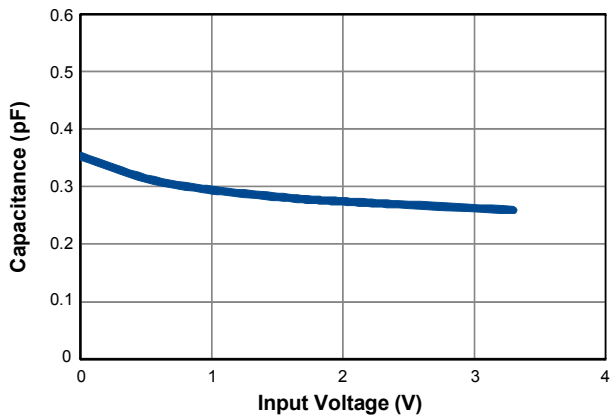

IEC61000-4-5 Surge 8/20 μs
(I/O Pin to GND and GND to I/O Pin)

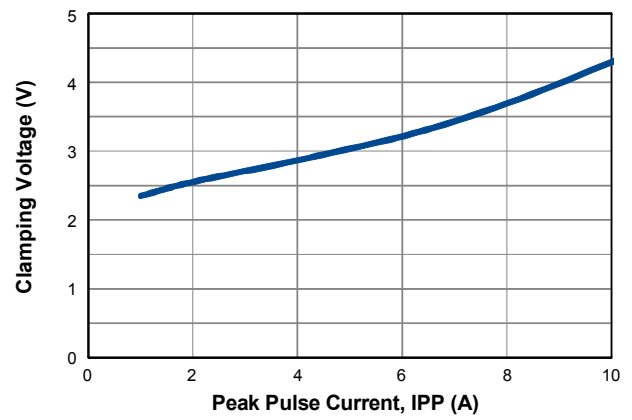

Typical Characteristics (Continued)

HDMI Eye-Diagram (16 Gbps)

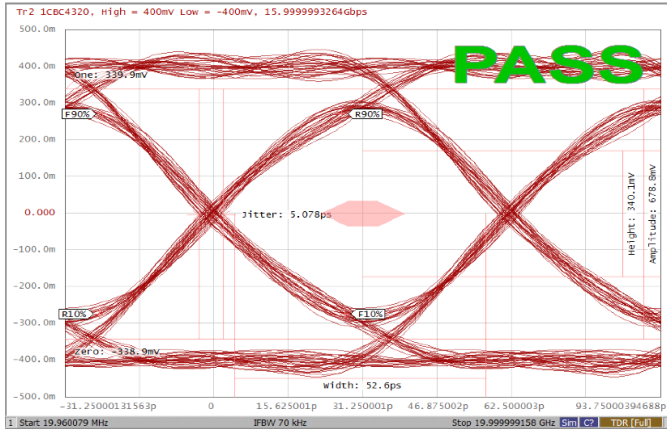

USB 3.1 Gen2 Eye-Diagram (10 Gbps)

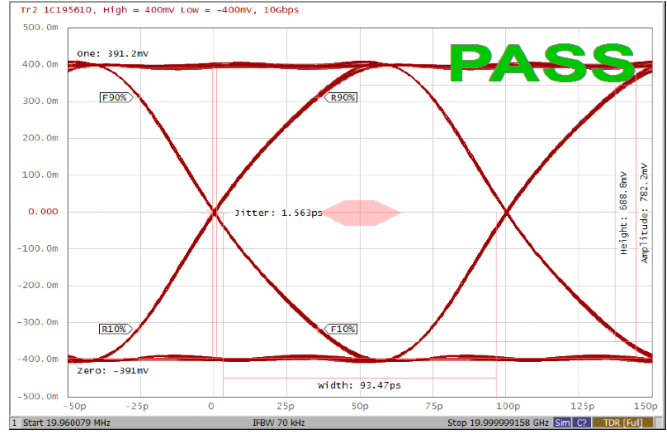

Insertion Loss (S21, I/O to GND)

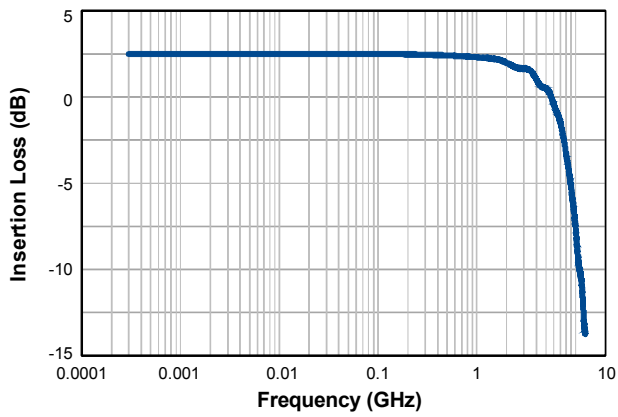

LEGAL DISCLAIMER

Applications or uses as critical components in life support devices or systems are not authorized. AOS does not assume any liability arising out of such applications or uses of its products. AOS reserves the right to make changes to product specifications without notice. It is the responsibility of the customer to evaluate suitability of the product for their intended application. Customer shall comply with applicable legal requirements, including all applicable export control rules, regulations and limitations.

AOS' products are provided subject to AOS' terms and conditions of sale which are set forth at:

http://www.aosmd.com/terms_and_conditions_of_sale

LIFE SUPPORT POLICY

ALPHA AND OMEGA SEMICONDUCTOR PRODUCTS ARE NOT AUTHORIZED FOR USE AS CRITICAL COMPONENTS IN LIFE SUPPORT DEVICES OR SYSTEMS.

As used herein:

1. Life support devices or systems are devices or systems which, (a) are intended for surgical implant into the body or (b) support or sustain life, and (c) whose failure to perform when properly used in accordance with instructions for use provided in the labeling, can be reasonably expected to result in a significant injury of the user.
2. A critical component in any component of a life support, device, or system whose failure to perform can be reasonably expected to cause the failure of the life support device or system, or to affect its safety or effectiveness.