

General Description

The AOZ1017AI evaluation board is a fully assembled and tested circuit board built with the AOZ1017AI buck regulator IC. It outputs an adjustable voltage up to 3A of continuous current. The evaluation board requires an input voltage from 4.5 to 16V. The output voltage is preset at 3.3V and can be adjusted down to 0.8V.

The AOZ1017AI-EVB circuit has features like current limit, short circuit protection, input under voltage lock out, internal soft start and thermal shut down. It operates at a fixed 500kHz switching frequency. The integrated internal MOSFET minimizes component count, board area and total cost.

The AOZ1017AI-EVB demonstrates the simple buck converter design. Only one resistor value change is needed for different output voltage designs. The AOZ1017AI-EVB also supports single layer board design.

Features

- 4.5V to 16V operating input voltage range
- Output voltage preset to 3.3V, adjustable to as low as 0.8V
- 3A continuous output current
- Fixed 500kHz PWM operation
- Internal soft start
- Cycle-by-cycle current limit
- Short-circuit protection
- Thermal shutdown
- Enable single layer board with all ceramics output capacitor design

Applications

- Point of load DC/DC conversion
- PCIe graphics cards
- Set top boxes
- DVD drives and HDD
- LCD panels
- Cable modems
- Telecom/Networking/Datacom equipment

Evaluation Board Schematic

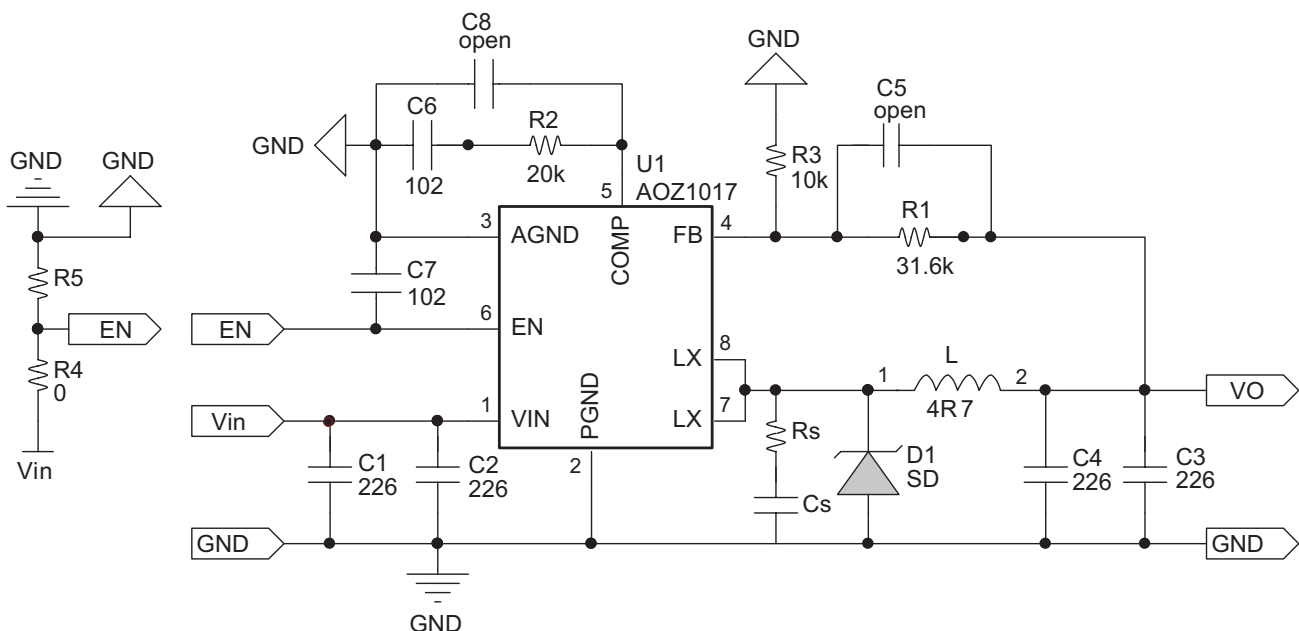

Table 1. Component List

Ref Designator	Part Number	Description	Manufacturer
C1, C2, C3, C4	GRM32ER61E226KE15L	Cap, 22μF/25V, 1210, X5R, 10%	muRata
C5, C8	Open	Cap, 0603	TDK, muRata
C6, C7	C1608C0G1H102J	Cap, 1nF/50V, 0603, X7R 10%	TDK
	GRM188R71H102KA01D		muRata
Cs	GRM188R71H102KA01D	Cap, 1nF/50V, 0603, X7R, 10%	muRata
D1	MBRS540	Schottky Diode	ON Semi
L	VLF10045-4R7M6R1	Inductor, 4.7μH, 6.1A	muRata
R1	31.6k	Res, 31.6k, 0603, 1%	
R2	20k	Res, 20k, 0603, 1%	
R3	10k	Res, 10k, 0603, 5%	
R4	0	Res, 0, 0603	
R5	Open	Res, 0603, 5%	
Rc	20k	Res, 20k, 0603, 5%	
Rs	3R3	Res, 3.3, 1206, 1%	
U1	AOZ1017AI	IC, MAX 3A, SO8	AOS

Output voltage is set by R1: $R1 = R2 \cdot (V_{out} - 0.8) / 0.8$. Table 2 below shows the value of R1 at typical output voltages.

Table 2.

Vout (V)	R1 (kΩ)	R2 (kΩ)
0.8	1	Open
1	2.49	10
1.2	4.99	10
1.5	8.66	10
1.8	12.7	10
2.5	21.5	10
3.3	31.6	10
5	52.3	10

PCB Layout

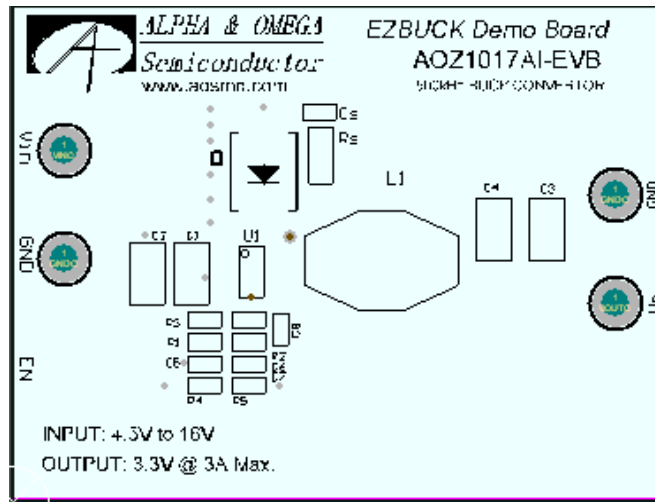

Figure 1. Top Silk Screen

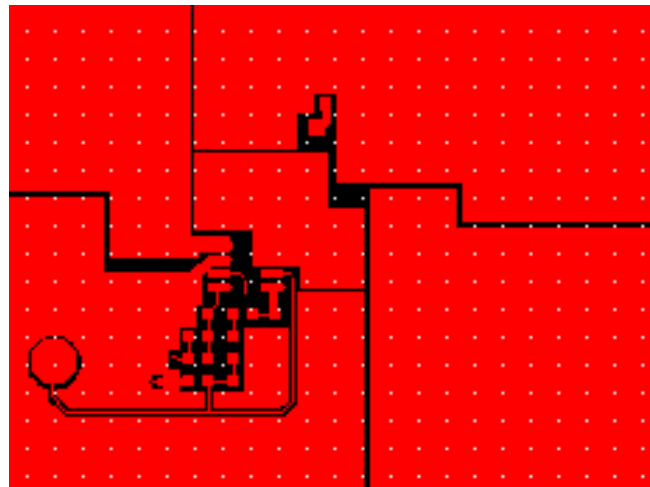

Figure 2. Top Layer

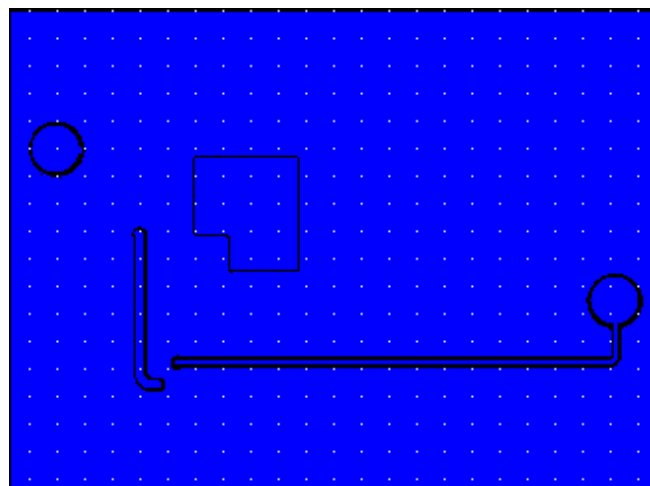

Figure 3. Bottom Layer

Quick Start Guide

1. Connect the terminals of load to Vout and GND port.
2. Connect the DC power supply to Vin and GND port. Set DC power supply voltage to between 4.5V and 16V.
3. EN pin is connected to Vin via a 00hm resistor in the demo board. If a separate enable signal is desired, connect EN pin to any voltage source between 2.0V and 16V.
4. Measure input voltage at the Vin and GND ports to eliminate the effect of voltage drop on the wire between DC power supply and evaluation board.
5. Measure output voltage at the Vout and GND ports to eliminate the effect of voltage drop on the wire between load and evaluation board.
6. Use an oscilloscope to monitor the input ripple voltage across input capacitor C2.
7. Use an oscilloscope to monitor the output ripple voltage across output capacitor C3.

Note:

When testing the ripple voltage, remove the cap of the voltage probe and touch the probe tip directly across the Vin or Vout and GND terminals, as shown in Figure 4.

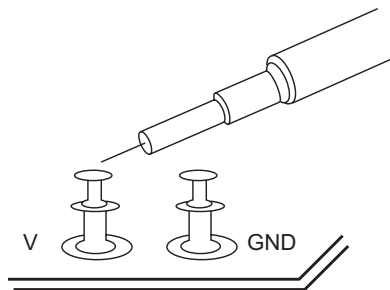

Figure 4. Voltage Ripple Test

Alpha & Omega Semiconductor reserves the right to make changes at any time without notice.

LIFE SUPPORT POLICY

ALPHA & OMEGA SEMICONDUCTOR PRODUCTS ARE NOT AUTHORIZED FOR USE AS CRITICAL COMPONENTS IN LIFE SUPPORT DEVICES OR SYSTEMS.

As used herein:

1. Life support devices or systems are devices or systems which, (a) are intended for surgical implant into the body or (b) support or sustain life, and (c) whose failure to perform when properly used in accordance with instructions for use provided in the labeling, can be reasonably expected to result in a significant injury of the user.

2. A critical component in any component of a life support, device, or system whose failure to perform can be reasonably expected to cause the failure of the life support device or system, or to affect its safety or effectiveness.