

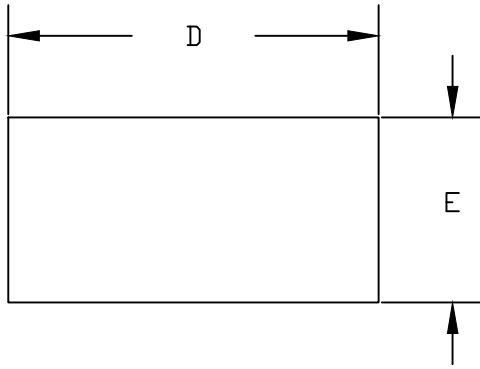

DFN0.6x0.3A_2L_EP2_S PACKAGE OUTLINE

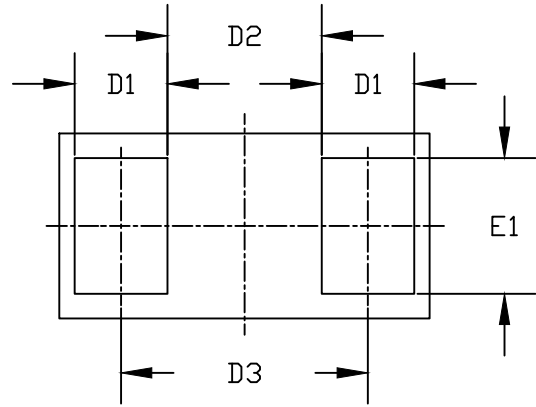

Top View



Bottom View

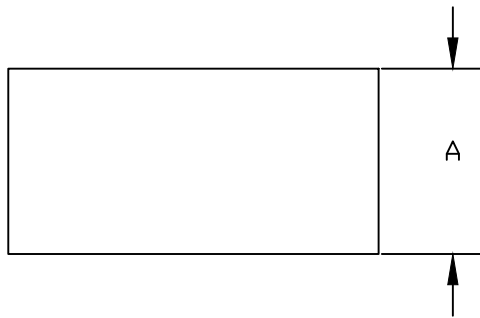

Side View

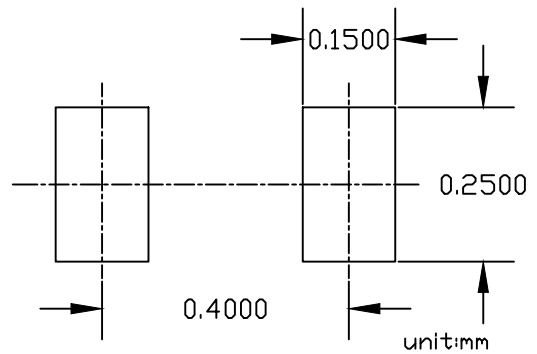

RECOMMEND LAND PATTERN

SYMBOLS	DIMENSIONS IN MILLIMETERS			DIMENSIONS IN INCHES		
	MIN	NOM	MAX	MIN	NOM	MAX
A	0.285	0.30	0.315	0.0112	0.0118	0.0124
D	0.575	0.60	0.625	0.0226	0.0236	0.0246
D1	0.12	0.15	0.18	0.0047	0.0059	0.0071
D2	0.20	0.25	0.30	0.0079	0.0098	0.0118
D3	---	0.38	---	---	0.0150	---
E	0.275	0.30	0.325	0.0108	0.0118	0.0128
E1	0.19	0.22	0.25	0.0075	0.0087	0.0098

NOTE

1. ALL DIMENSIONS ARE IN MILLIMETERS.
2. DIMENSIONS ARE INCLUSIVE OF PLATING.
3. PACKAGE BODY SIZES EXCLUDE MOLD FLASH AND GATE BURRS.
MOLD FLASH AT THE NON-LEAD SIDES SHOULD BE LESS THAN 6MIL EACH.
4. CONTROLLING DIMENSION IS MILLIMETER. CONVERTED INCH DIMENSIONS ARE NOT NECESSARILY EXACT.
5. PADDLE EXPOSED ON BOTTOM.