

## General Description

The AOZ1390DI ideal diode switch is intended for applications that require reverse current protection and “Power ORing” supply configuration. The input operating voltage range is between 3.3V and 23 V, and both VIN and VOUT terminals are rated at 30V Absolute Maximum. The AOZ1390DI provides under-voltage lockout, over-voltage, and over-temperature protection. The FLTB pin flags thermal shutdown, short circuit protection and over-voltage faults.

AOZ1390DI is the ideal solution for multi-port Type-C PD current sinking application. The Ideal Diode TRCB feature prevents VIN to rise due to reverse current flow from VOUT under all conditions. There is also a Limited Power Source (LPS) protection feature to prevent excessive power flow through the device from other ports that are faulty or damaged. A short is detected if VIN voltage is higher than threshold voltage when the device is disabled (EN = Low). There is a 2.5s blanking time before the device pulls the LPSB output low to shut down other ports using their DISB pins.

An internal soft-start circuit controls inrush current due to highly capacitive loads and the slew rate can be adjusted using an external capacitor. The integrated back-to-back MOSFET offer industry’s lowest ON resistance and highest SOA to safely handle high current and a wide range of output capacitances on VOUT.

The AOZ1390DI is available in a thermally enhanced 3.5 mm x 3 mm DFN-14 package which can operate over -40 °C to +125 °C junction temperature range.

## Features

- 18 mΩ typical ON resistance
- 3.3 V to 23 V operating input voltage
- VIN and VOUT rated at 30 V abs max.
- Ideal Diode True Reverse Current Blocking (IDTRCB)
- Fast recovery from reverse current condition
- Support Limited Power Source (LPS)
- Programmable Soft-Start
- VIN Under-Voltage Lockout (UVLO)
- VIN Over-Voltage Protection (OVP)
- Thermal Shutdown Protection (TSD)
- Short Circuit Protection (SCP)
- VIN Discharge
- IEC61000-4-5: 55 V on VOUT, No output capacitor
- Thermally Enhanced DFN3.5x3-14L package

## Applications

- USB PD power source switch
- Smart phone and tablet
- Notebook, ultrabook and desktops



## Typical Applications

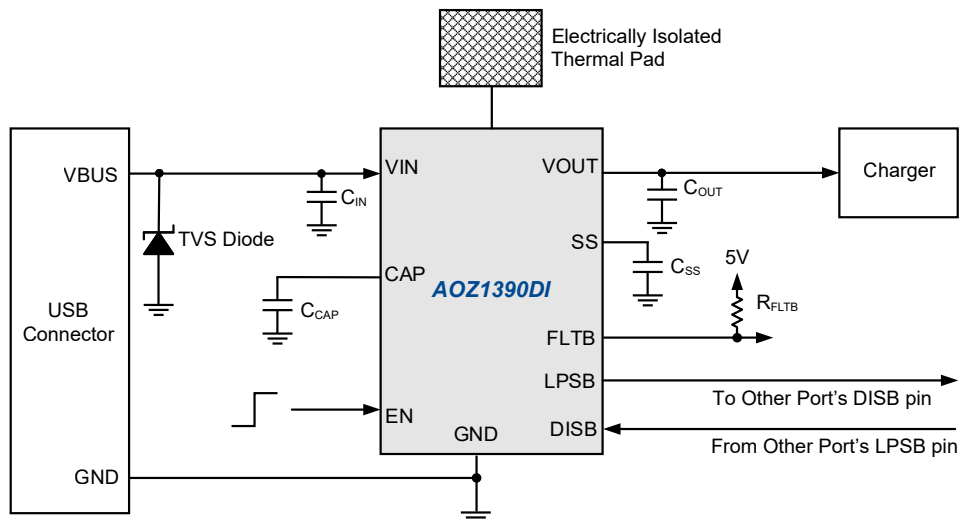

Typical Multiple Ports Application

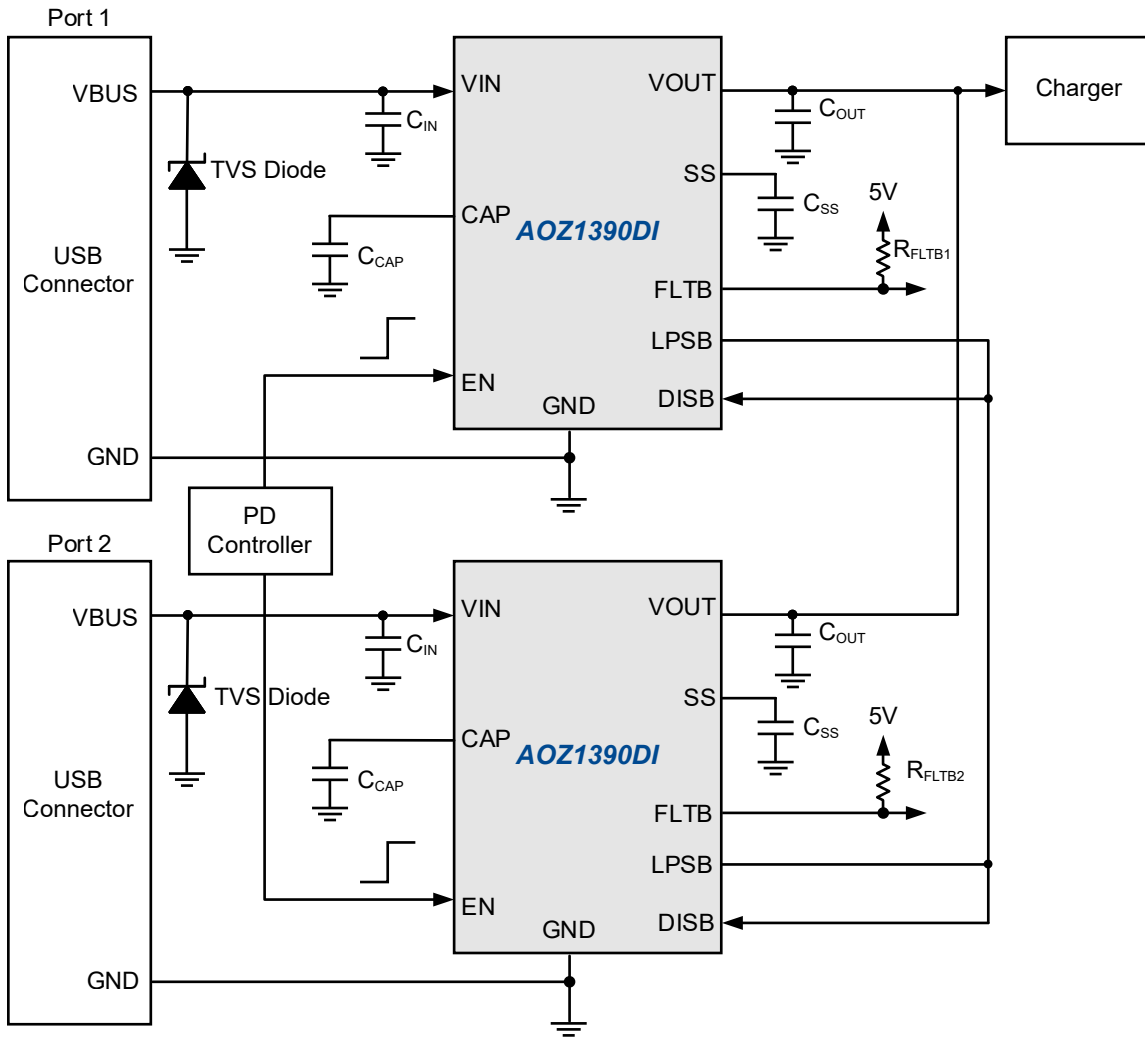

## Ordering Information

Part Number	Fault Recovery	Junction Temperature Range	Package	Environmental
AOZ1390DI-01*	Auto-Restart	-40°C + 125°C	DFN3.5x3-14L	RoHS
AOZ1390DI-02	Latch-Off	-40°C + 125°C	DFN3.5x3-14L	RoHS

\* Contact local Sales for more information



AOS products are offered in packages with Pb-free plating and compliant to RoHS standards. Please visit [www.aosmd.com/media/AOSGreenPolicy.pdf](http://www.aosmd.com/media/AOSGreenPolicy.pdf) for additional information.

## Pin Configuration

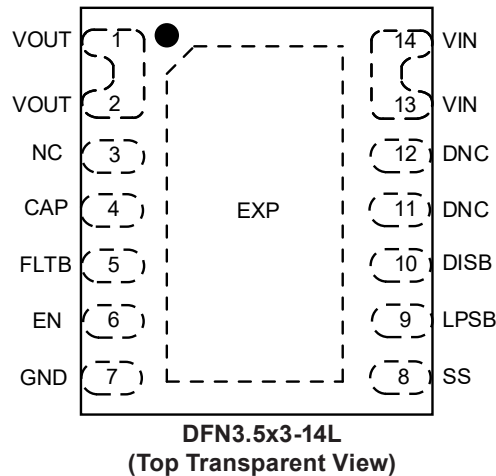

## Pin Description

Pin Number	Pin Name	Pin Function
1, 2	VOUT	Output pins. Connect to internal load.
3	NC	No connect.
4	CAP	Connect a 1 nF Capacitor to GND. No external load is allowed on this pin.
5	FLT B	Fault Indicator, Active low, open-drain output.
6	EN	Enable, Active.
7	GND	Ground.
8	SS	Soft-start pin. Connect a capacitor CSS from SS to GND to set the soft-start time.
9	LPSB	LPS Fault Output Indicator. LPSB will pull low if VIN exceeds LPBS detection voltage threshold when the part is disabled (EN=Low).
10	DISB	Disable Bar input pin. DISB has an internal 10 $\mu$ A pull-up current source. For 3-port or less systems tie all DISB pins together. Once DISB pulls low the power MOSFET will turn off but IC will remain active. Only cycling VIN can re-enable the devices.
11	DNC	Do not connect. No external connections allowed.
12	DNC	Do not connect. Internally connected to common drain node of power switch.
13, 14	VIN	Connect to adapter or power input. Place a 10 $\mu$ F capacitor from VIN to GND. When EN goes low, VIN will internally discharge to GND.
EXP	EXP	Exposed Thermal Pad. It is the common drain node for the power switches and it must be electrically isolated. Solder to a metal surface directly underneath the EXP and connect to floating copper thermal pads on multiple PCB layers through many VIAs. For best thermal performance, make the floating copper pads as large as possible.

## Absolute Maximum Ratings

Exceeding the Absolute Maximum ratings may damage the device.

Parameter	Rating
VIN, VOUT to GND	-0.3 V to +30 V
EN, SS, FLT_B, DISB, LPSB to GND	-0.3 V to +6 V
CAP to VIN	-0.3 V to +6 V
Junction Temperature (T <sub>J</sub> )	+150 °C
Storage Temperature (T <sub>S</sub> )	-65 °C to +150 °C
ESD Rating HBM All Pins	±2 kV
IEC 61000-4-2: VIN and VOUT Pins	±8 kV

## Recommended Operating Conditions

The device is not guaranteed to operate beyond the Maximum Recommended Operating Conditions.

Parameter	Rating
VIN, VOUT to GND	3.3V to 23 V
EN, FLT_B, DISB, LPSB to GND	0 V to 5.5 V
SS	0 V to 3 V
CAP to VIN	0 V to 5.5 V
Switch Current (I <sub>SW</sub> )	0 A to 8 A
Peak Switch Current (I <sub>SW</sub> ) for 10 ms @ 2% Duty Cycle	20 A
Junction Temperature (T <sub>J</sub> )	-40 °C to +125 °C
Package Thermal Resistance 3.5x3 DFN-14 (θ <sub>JC</sub> ) 3.5x3 DFN-14 (θ <sub>JA</sub> )	2 °C/W 36 °C/W

## Electrical Characteristics

T<sub>A</sub> = 25 °C, VIN = 20V, EN = 5 V, C<sub>CAP</sub> = 1 nF, C<sub>IN</sub> = 10 μF, C<sub>OUT</sub> = 10 μF, C<sub>SS</sub> = 5.6 nF, unless otherwise specified.

Symbol	Parameter	Conditions	Min	Typ	Max	Units
<b>General</b>						
V <sub>VIN</sub>	Input Supply Voltage		3.3		23	V
V <sub>UVLO</sub>	Under-voltage Lockout Threshold	VIN rising	2.85		3.25	V
V <sub>UVLO_HYS</sub>	Under-voltage Lockout Hysteresis			150		mV
I <sub>VIN_ON</sub>	Input Quiescent Current	IOUT = 0A		650	910	μA
I <sub>VIN_OFF</sub>	Input Shutdown Current	IOUT = 0A, EN = 0V		75	150	μA
I <sub>VOUT_OFF</sub>	Output Leakage Current	VOUT = 20A, VIN = 0V, EN = 0V		48	100	μA
R <sub>ON_20V</sub>	Switch ON-Resistance <sup>(1)</sup>	IOUT > 2.25A		18		mΩ
R <sub>ON_5V</sub>		VIN = 5V, IOUT > 2.25A		19		mΩ
V <sub>EN_H</sub>	EN Input High Threshold	EN rising			1.4	V
V <sub>EN_L</sub>	EN Input Low Threshold	EN falling	0.4			V
I <sub>EN_BIAS</sub>	EN Pin Input Pull-up Current	EN = 1.8V		2.5		μA
V <sub>FLT_B_LO</sub>	FLT_B Pull-down Voltage	FLT_B sinking 3mA			0.3	V
<b>Input Over-Voltage Protection (OVP)</b>						
V <sub>OVP</sub>	Over-voltage Protection Threshold	VIN rising	23.1	24	25	V
V <sub>OVP_HYS</sub>	Over-voltage Protection Hysteresis	AOZ1390DI-01 only		300		mV
t <sub>OVP_DEB</sub>	Over-voltage Protection Debounce Time			512		μs

### Notes:

- RON is tested at 1A in test mode to bypass ideal diode regulation

## Electrical Characteristics

$T_A = 25^\circ\text{C}$ ,  $V_{IN} = 20\text{V}$ ,  $EN = 5\text{V}$ ,  $C_{CAP} = 1\text{nF}$ ,  $C_{IN} = 10\ \mu\text{F}$ ,  $C_{OUT} = 10\ \mu\text{F}$ ,  $C_{SS} = 5.6\text{nF}$ , unless otherwise specified.

Symbol	Parameter	Conditions	Min	Typ	Max	Units
<b>Ideal Diode True Reverse-Current Blocking (IDTRCB)ent Blocking</b>						
$V_{ID\_REG}$	Ideal diode voltage regulation	$V_{IN} - V_{OUT}$		35		mV
<b>Dynamic Timing Characteristics</b>						
$t_{D\_ON}$	Turn-On Delay Time	From EN rising edge to VOUT reaching 10% of $V_{IN}$ .		10		ms
$t_{ON}$	Turn-On Rise Time	VOUT from 10% to 90%		2		ms
$t_{OFF}$	Turn-Off Fall Time	From EN falling Edge to $I_{OUT} = 0\text{A}$		32		$\mu\text{s}$
$t_{REC}$	Auto Restart Interval after OVP or TSD Fault Conditions	AOZ1390DI-01 only		64		ms
$t_{SCP\_REC\_01}$	Auto Restart Interval upon Startup Short Circuit Condition	AOZ1390DI-01 only		64		ms
$t_{SCP\_REC\_02}$	Auto Restart Interval at Each Retry upon Startup Short Circuit Condition	AOZ1390DI-02 only. Latch-off after 4 times retry		2		ms
<b>Thermal Shutdown (TSD)</b>						
$T_{SD}$	Thermal Shutdown Threshold	Temperature rising		140		$^\circ\text{C}$
$T_{SD\_HYS}$	Thermal Shutdown Hysteresis	Temperature falling AOZ1390DI-01 only		30		$^\circ\text{C}$
<b>VIN Discharge</b>						
$V_{DISC\_DET\_FALL}$	VIN falling edge threshold for VIN discharge turn on			4.25	4.4	V
$V_{DISC\_DET\_RISE}$	VIN rising edge threshold for VIN discharge turn off				4.5	V
$V_{DISC\_MIN}$	VIN Discharge off voltage	$V_{OUT} = 5\text{V}$			0.8	V
$t_{DISC\_TIMEOUT}$	VIN Discharge Current Time Out	From EN falling edge to VIN Discharge current off		1		s
$I_{VIN\_DISC}$	VIN Discharge Current			2.5		mA
<b>Limited Power Source Function (LPS)</b>						
$V_{LPSB\_VIN\_DET}$	LPSB Detection Voltage Threshold	VIN rising, $EN = 0\text{V}$	6.0	6.3		V
$V_{LPSB\_VIN\_HYS}$	LPSB Detection Voltage Hysteresis	VIN falling		150		mV
$t_{LPSB}$	LPSB Debounce Time	From $V_{IN} > V_{LPSB\_VIN\_DET}$ to $LPSB < 0.3\text{V}$ , $EN = 0\text{V}$		2.5		s
$V_{LPSB\_LO}$	LPSB Pull-Down Voltage	LPSB sinking 3 mA			0.3	V
$I_{DISB\_BIAS}$	DISB pull up current			10		$\mu\text{A}$
$V_{DISB\_H}$	DISB Input High Threshold	DISB rising			1.4	V
$V_{DISB\_L}$	DISB Input Low Threshold	DISB falling	0.4			V
$t_{DISB\_RESP}$	DISB Detection Response Time to MOSFET Off			160		$\mu\text{s}$

### Functional Block Diagram

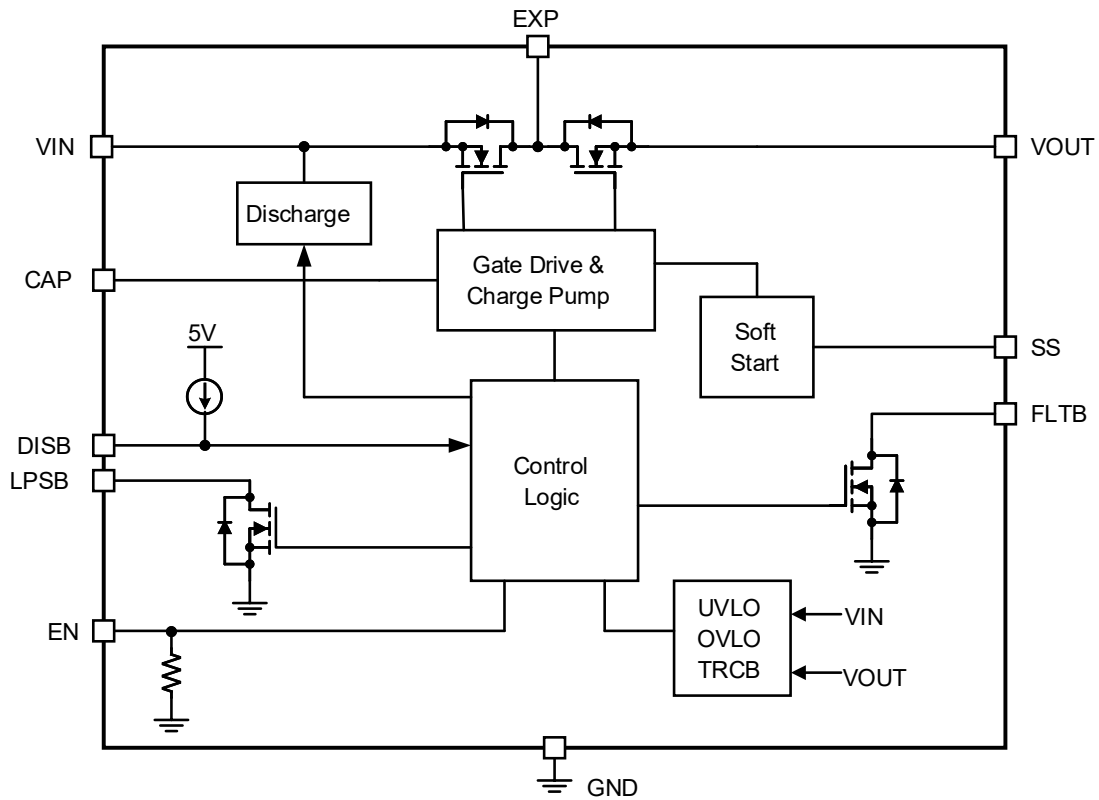

## Timing Diagrams

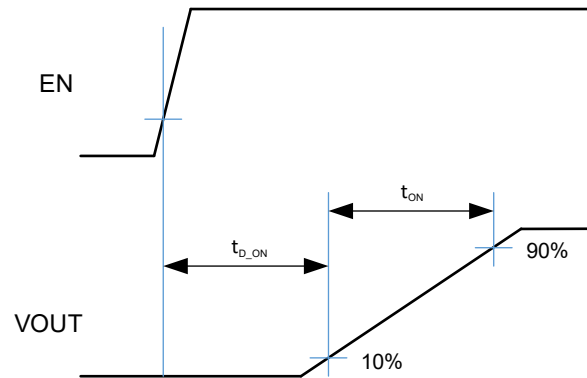

Figure 1. Turn-on Delay and Turn-on Time

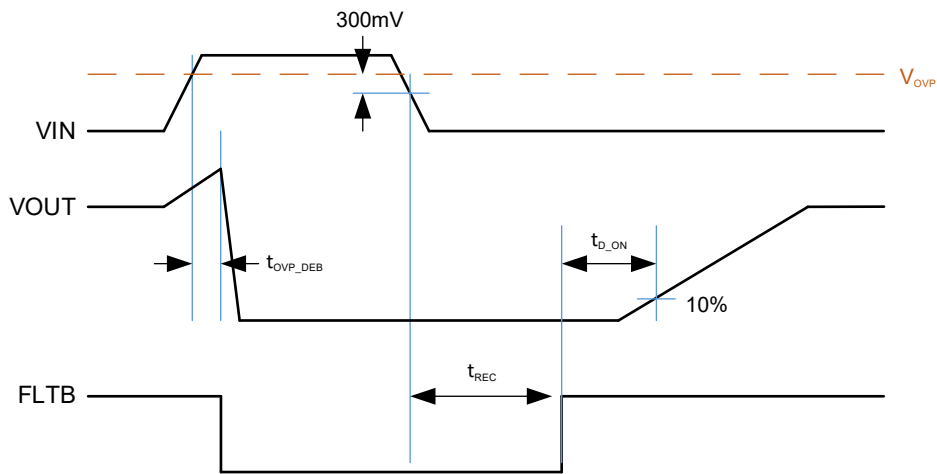

Figure 2. Over-Voltage Protection (AOZ1390DI-01)

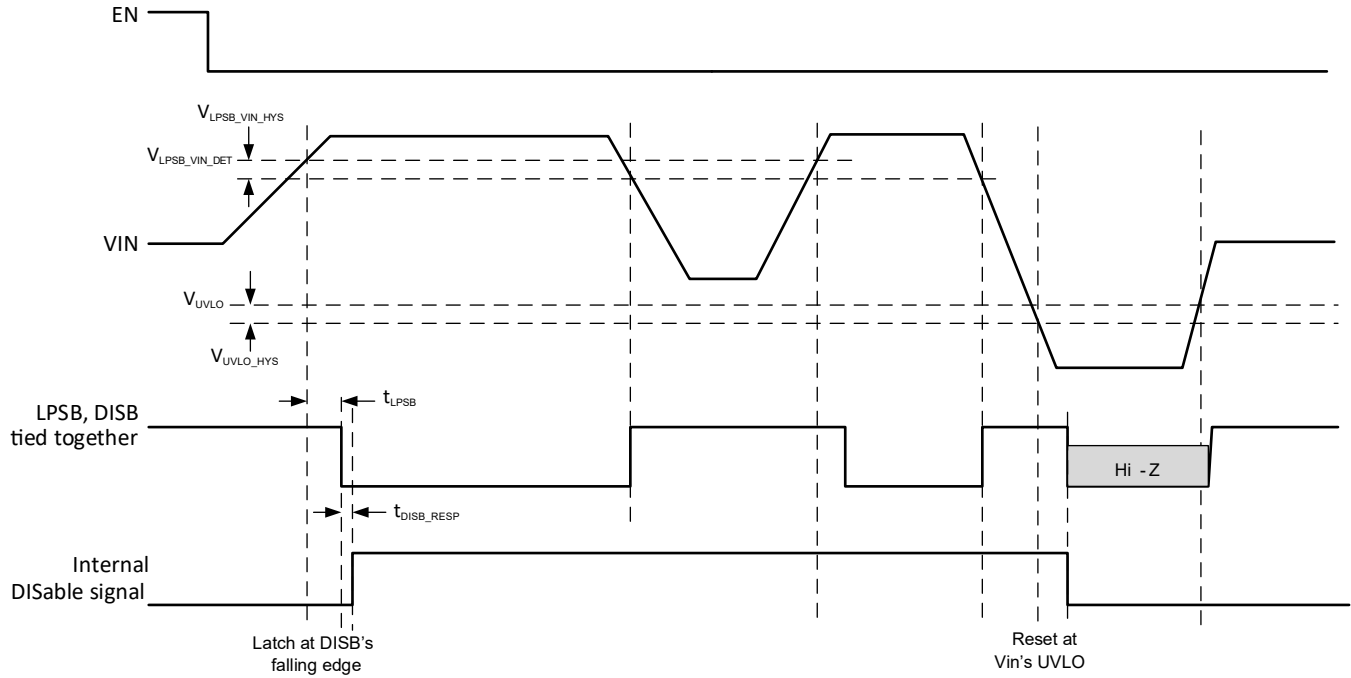

Figure 3. Limited Power Supply Protection



## Typical Characteristics

$T_A = 25^\circ\text{C}$ ,  $V_{IN} = 20\text{V}$ ,  $V_{EN} = 5\text{V}$ ,  $C_{IN} = 10\mu\text{F}$ ,  $C_{OUT} = 10\mu\text{F}$ ,  $C_{SS} = 5.6\text{nF}$ ,  $C_{CAP} = 1\text{nF}$ , unless otherwise specified.

**Soft Start Delay Time**  
( $V_{IN} = 4\text{V}$ ,  $R_{OUT} = 1.45\Omega$ )

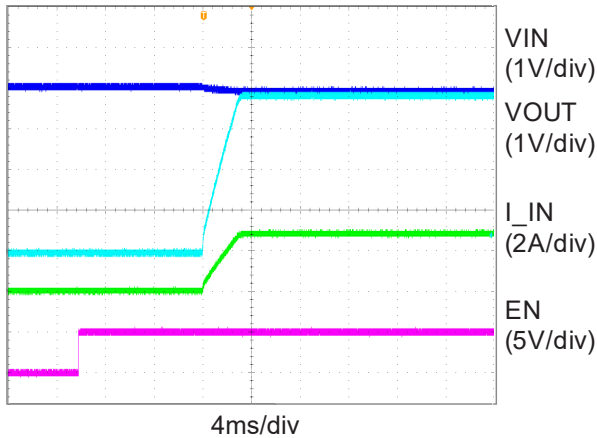

**Soft Start Delay Time**  
( $V_{IN} = 20\text{V}$ ,  $R_{OUT} = 1.45\Omega$ )

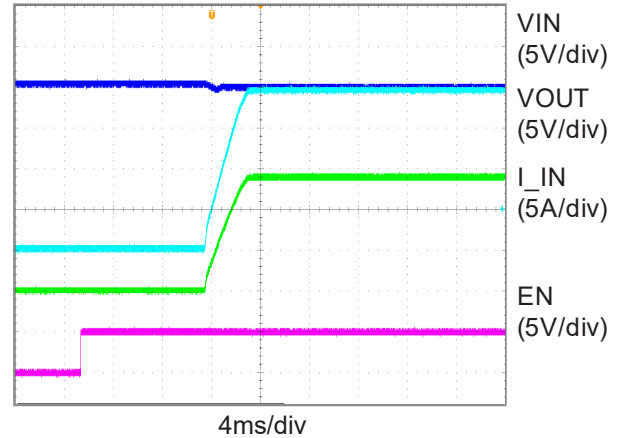

**Soft Start Ramp**  
( $V_{IN} = 5\text{V}$ ,  $R_{OUT} = 0.625\Omega$ )

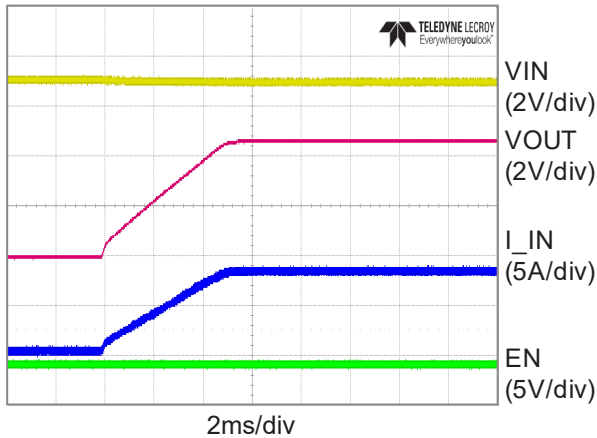

**Soft Start Ramp**  
( $V_{IN} = 20\text{V}$ ,  $R_{OUT} = 2.5\Omega$ )

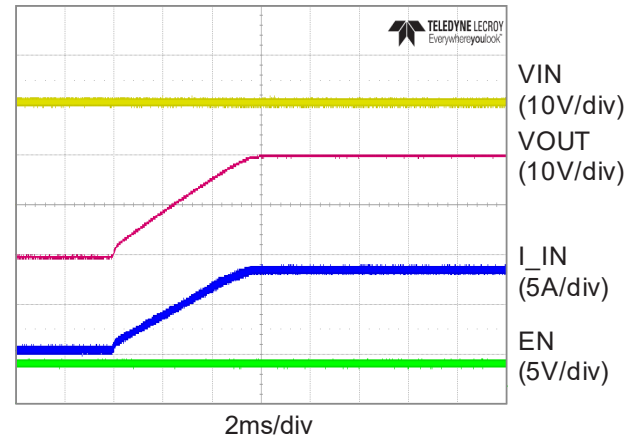

**Shut Down**  
( $V_{IN} = 5\text{V}$ ,  $R_{OUT} = 0.625\Omega$ )

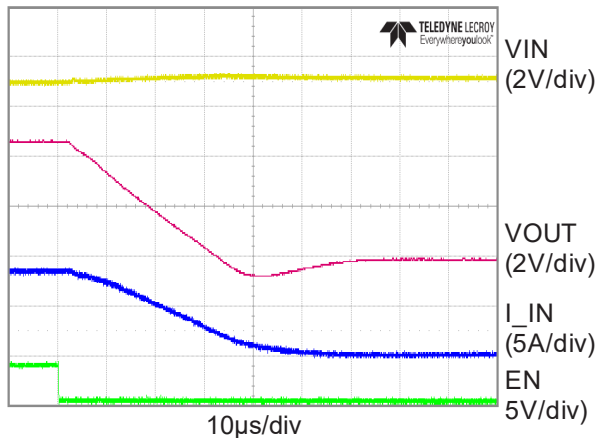

**Shut Down**  
( $V_{IN} = 20\text{V}$ ,  $R_{OUT} = 2.5\Omega$ )

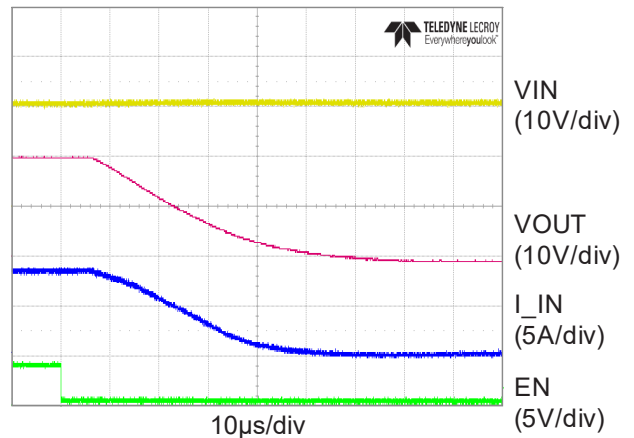

## Typical Characteristics

$T_A = 25^\circ\text{C}$ ,  $V_{IN} = 20\text{V}$ ,  $EN = 5\text{V}$ ,  $C_{IN} = 10\mu\text{F}$ ,  $C_{OUT} = 10\mu\text{F}$ ,  $C_{SS} = 5.6\text{nF}$ ,  $C_{CAP} = 1\text{nF}$ , unless otherwise specified.

**True Reverse Current Blocking – Entry  
(3A Load)**

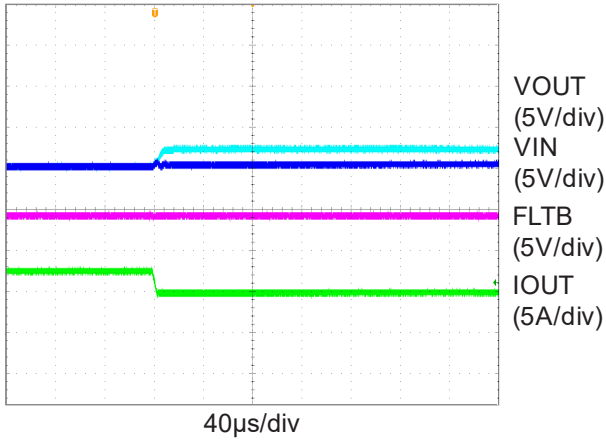

**True Reverse Current Blocking – Exit  
(3A Load)**

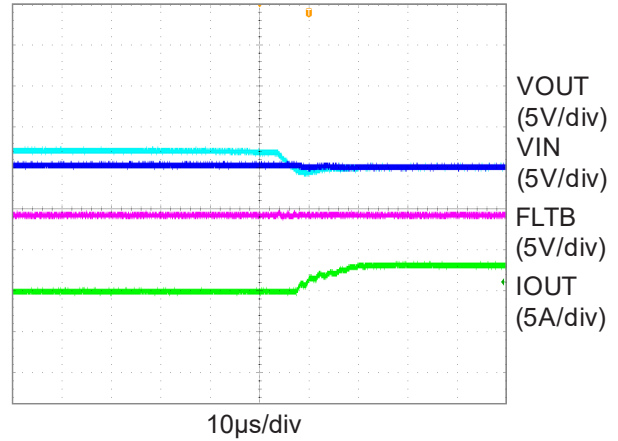

**Over Voltage Protection**

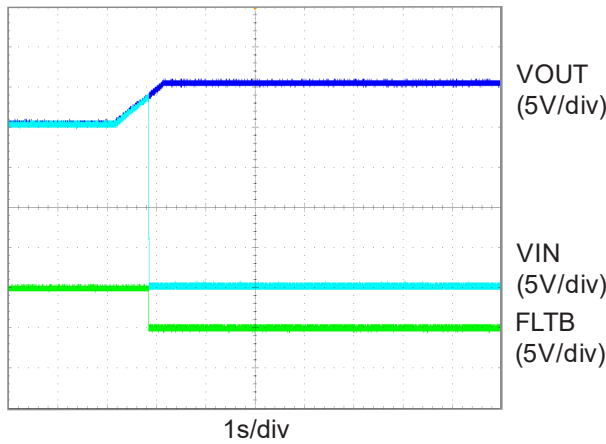

**ORing Operation  
(EN1=EN2=high, IC2:12V, IC1: 5V → 20V → 5V)  
VOUT1 and VOUT2 tied together**

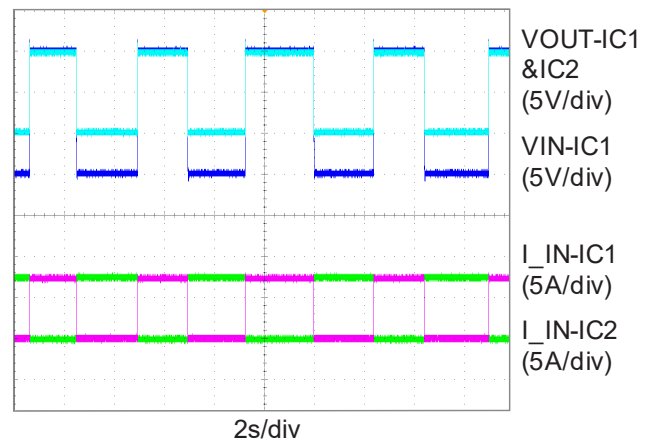

**SCP during Startup  
AOZ1390DI-02**

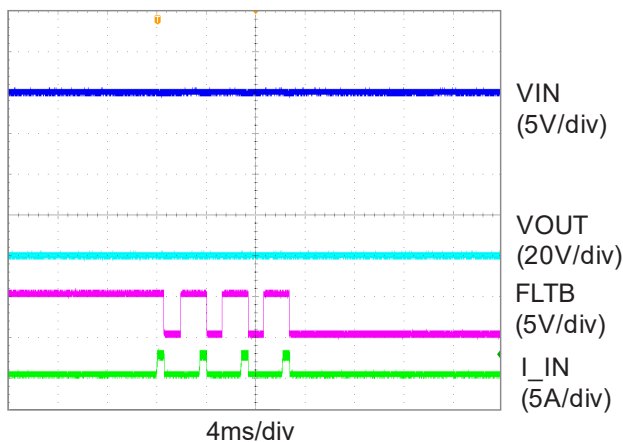

**Limited Power Source Operation  
(VIN: 5V → 10V)**

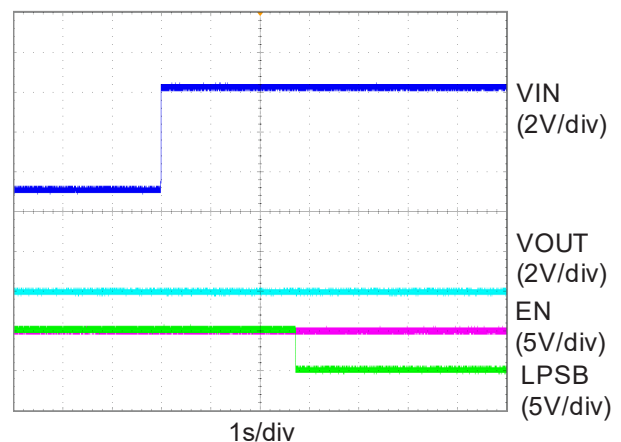

## Typical Characteristics

$T_A = 25^\circ\text{C}$  unless otherwise specified.

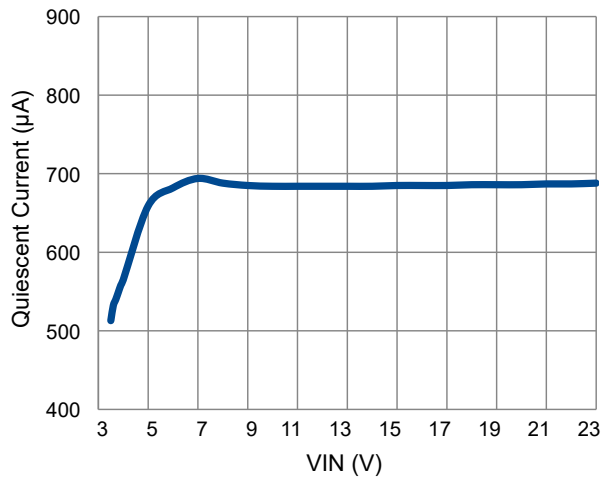

Figure 4. Quiescent Current vs VIN

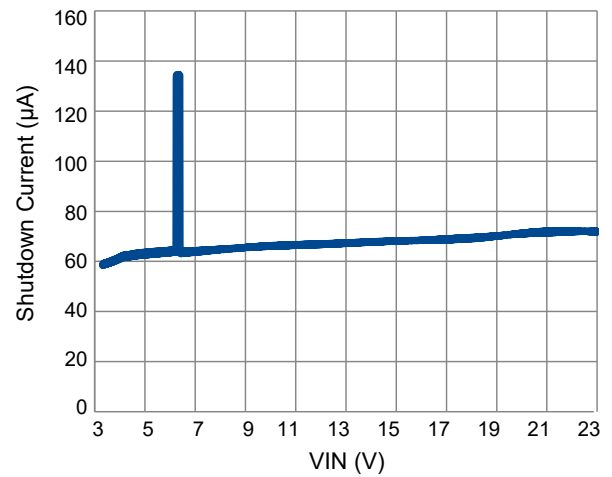

Figure 5. Shutdown Current vs. VIN  
(Note: Current spike around 6.3V is for LPBS function and only sustains for  $t_{LPBS}$ )

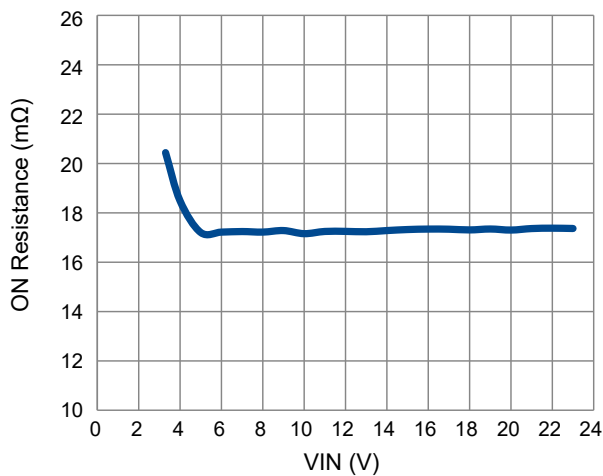

Figure 6. On Resistance vs VIN

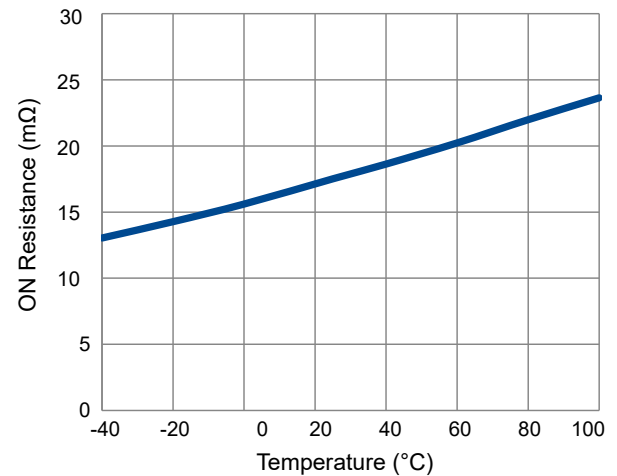

Figure 7. On Resistance vs Temperature (VIN = 20 V)

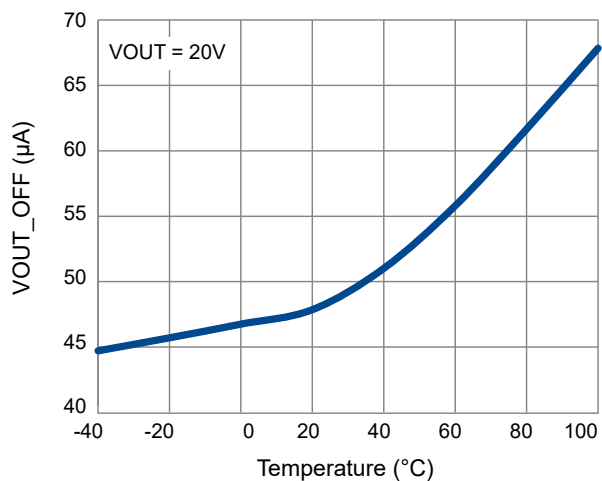

Figure 8. VOUT Leakage Current vs. Temperature  
(VOUT=20V, VIN=0V, EN=0V)

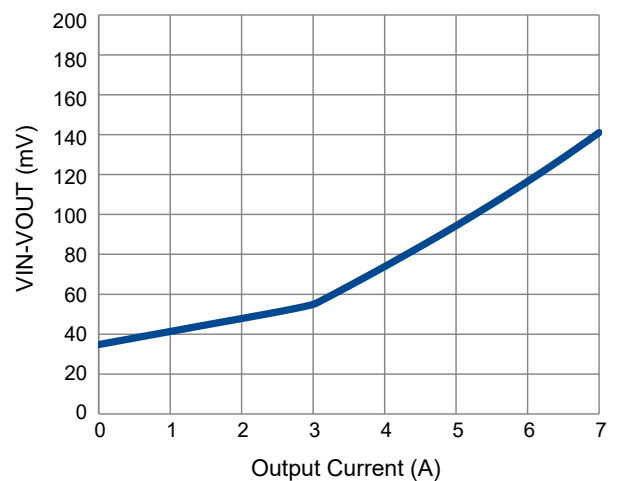

Figure 9. VIN-VOUT vs. Output Current

## Functional Description

The AOZ1390DI is a high-side protection switch with adjustable soft-start, over-voltage and over-temperature protections. It is capable of operating from 3.3V to 23V and rated up to 8A.

The internal power switch consists of 2 back-to-back connected N-channel MOSFETs. When the switch is enabled, the overall resistance between VIN and VOUT is only 18mΩ when IOUT > 3.5A, minimizing power loss and heat generation. The back-to-back configuration of MOSFETs completely isolates VIN and VOUT when the switch is turned off, preventing leakage between the two pins.

## Power Delivery Capability

During start-up, the voltage at VOUT linearly ramps up to the VIN voltage over a period of time set by the soft-start time. This ramp time is referred to as the soft-start time and is typically in milliseconds. Figure 10 illustrates the soft-start condition and power dissipation.

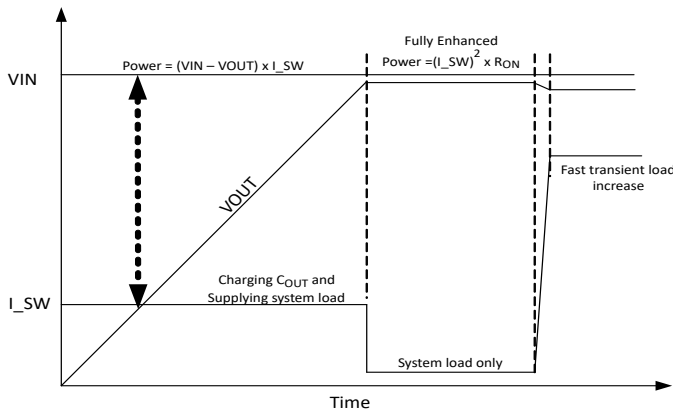

Figure 10. Soft Start Power Dissipation

During this soft-start time, there will be a large voltage across the power switch. Also, there will be current I\_SW through the switch to charge the output capacitance. In addition, there may be load current to the downstream system as well. This total current is calculated as:

$$I_{SW} = C_{OUT} \left( \frac{dV_{OUT}}{dt} \right) + I_{SYS}$$

In the soft-start condition, the switch is operating in the linear mode, and power dissipation is high. The ability to handle this power is largely a function of the power MOSFET linear mode SOA and good package thermal performance Rθ<sub>JC</sub> (Junction-to-Case) as the soft-start ramp time is in milliseconds. Rθ<sub>JA</sub> (Junction-to-Ambient), which is more a function of PCB thermal performance, doesn't play a role.

With a high-reliability MOSFET as the power switch and superior packaging technology, the AOZ1390DI is capable of dissipating this power. The power dissipated is:

$$Power\ Dissipation = I_{SW} \times (VIN - VOUT)$$

To calculate the average power dissipation during the soft-start period: ½ of the input voltage should be used as the output voltage will ramp towards the input voltage, as shown in Figure 10.

For example, if the output capacitance C<sub>OUT</sub> is 10 μF, the input voltage VIN is 20 V, the soft-start time is 2 ms, and there is an additional 1 A of system current (I<sub>SYS</sub>), then the average power being dissipated by the part is:

$$I_{SW} = 10\mu F \left( \frac{20V}{2ms} \right) + 1A = 1.1A$$

$$Average\ Power\ Dissipation = 1.1A \times \frac{20V}{2} = 11W$$

Referring to the SOA curve in Figure 11, the maximum power allowed for 2 ms is 120 W (6 A x 20 V or 12 A x 10 V). The AOZ1390DI power switch is robust enough to drive a large output capacitance with load in reasonable soft-start time.

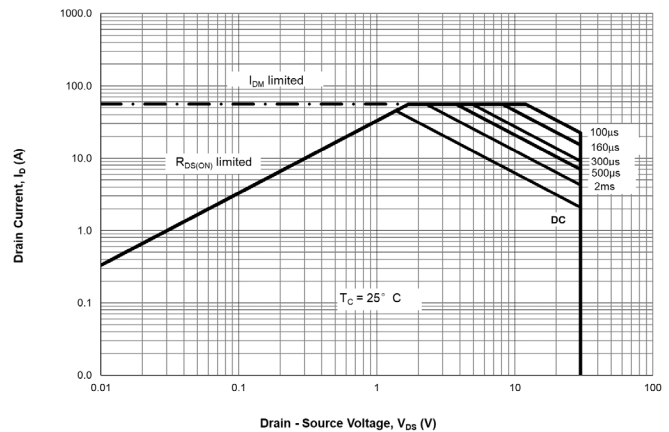

Figure 11. Safe Operating Area (SOA) curves for Power Switch

After soft-start is completed, the power switch is fully on, and it is at its lowest resistance. The power switch acts as a resistor. Under this condition, the power dissipation is much lower than the soft-start period. However, as this is a continuous current, a low on-resistance is required to minimize power dissipation. Attention must be paid to board layout so that losses dissipated in the power switch are dissipated to the PCB and hence the ambient.

With a low on-resistance of 18 mΩ, the AOZ1390DI provides the most efficient power delivery without much resistive power dissipation.

While Type C power delivery is limited to 20 V @ 5 A or a 100 W, many high-end laptops require peak currents far in excess of the 5 A. While the thermal design current (TDC) for a CPU may be low, peak current (ICCmax in the case of Intel and EDP in the case of AMD) of many systems is often 2 x thermal design current. These events are typical of short duration (< 2 ms) and low duty cycle, but they are important for system performance as a CPU/GPU capable of operating at several GHz can boost its compute power in those 2 ms peak current events. The AOZ1390DI can handle such short, high current, transient pulses without any reliability degradation, thus enhancing the performance of high-end systems when plugged into the Type C adaptor. The shorter the pulse and the lower the duty cycle, the higher the pulse current that the part can sustain. The part has enough time to dissipate the heat generated from the pulse current with longer off-time, as shown in Figure 12. For example, AOZ1390DI can maintain 20 A for 10 ms with a duty cycle of 2%.

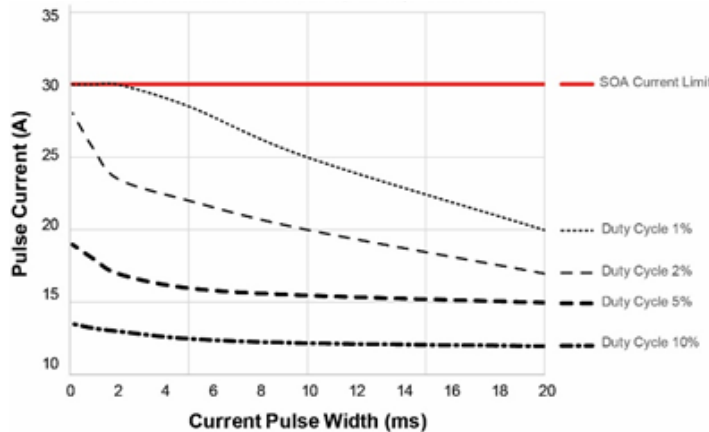

Figure 12. AOZ1390DI Power Switch Pulsed Current vs. Duration for a Given Duty Cycle

### Enable

The active high EN pin is the ON/OFF control for the power switch. The device is enabled when the EN pin is high and  $V_{IN} > V_{UVLO}$ . The EN pin must be driven to a logic high ( $V_{EN,H}$ ) or logic low ( $V_{EN,L}$ ) state to guarantee operation. AOZ1390DI draws about 75  $\mu$ A supply current when it is disabled.

### Input Under-Voltage Lockout (UVLO)

The internal control circuit is powered from VIN. The Under-Voltage Lock Out (UVLO) circuit monitors the voltage at the input pin (VIN) and only allows the power switches to turn on when it is higher than UVLO threshold ( $V_{UVLO}$ ).

### Over-Voltage Protection (OVP)

The voltages at VIN pin are constantly monitored once the device is enabled. In case the voltage exceeds the OVP threshold, over-voltage protection is activated:

1. If the power switch is on, it will be turned off after OVP debounce time ( $t_{OVP\_DEB}$ ) to isolate VOUT from VIN;
2. OVP will prevent power switch to be turned on if it is in off state;

In either case FLTB pin is pulled low to report the fault condition. The device can only be re-enabled by either toggling EN pin or cycling the input power supply.

### Ideal Diode True Reverse Current Blocking (IDTRCB)

When the device is on with no load or under light load conditions, AOZ1390DI regulates VOUT 35mV below VIN. As the load current is increased or decreased the device adjusts the gate drive to maintain the 35mV drop from VIN to VOUT. As the load current increases the device increases the gate drive until the gate is fully on and VOUT to VIN drop is determined by IR drop through the MOSFET. If for any reason VOUT increases such that VIN to VOUT drop is less than 35mV, the gate driver forces the switch to turn off.

### Thermal Shut Down Protection (TSD)

Thermal shutdown protects device from excessive temperature. The power switch is turned off when the die temperature reaches thermal shutdown threshold of 140 °C. There is a 30 °C hysteresis for the AOZ1390DI-01: The power switch is allowed to turn on again if die temperature drops below approximately 110 °C.

**AOZ1390DI-01(Auto-Restart version):** Once the TSD is removed, the power switch will be turned on again to restart after 64 ms ( $t_{REC}$ ) blanking time.

**AOZ1390DI-02 (Latch-Off version):** The device will latch off and only be turned on after either toggling the EN input logic to reset the device or cycling the input voltage.

### Soft Start Slew Rate Control

When EN pin is asserted logic high, the slew rate control circuitry applies a voltage on the gate of the power switch in a manner such that the output voltage is ramped up linearly until it reaches the input voltage level. The output ramp up time is programmed by an external soft-start capacitor (CSS). The following formula provides the estimated 10% to 90% ramp up time.

$$t_{ON} = \frac{C_{SS}}{0.0023} - 100$$

where  $C_{SS}$  is in nF and  $t_{ON}$  is in  $\mu$ s

## System Startup

The device is enabled when  $EN \geq 1.4\text{ V}$  and  $V_{IN}$  is higher than UVLO threshold ( $V_{UVLO}$ ). The device will check if any fault condition exists. If no fault exists, the power switch is turned on and  $V_{OUT}$  is then ramped up after enable delay ( $t_{D\_ON}$ ), controlled by the soft-start time ( $t_{ON}$ ) until  $V_{OUT}$  reaches  $V_{IN}$  voltage level. Soft start time can be programmed externally through SS input with a capacitor  $C_{SS}$  to control in-rush current.

## VIN Discharge

The  $V_{IN}$  discharge current is 2.5 mA. The discharge current is active when enable is low and the  $V_{IN}$  falls below  $V_{DISC\_DET\_FALL}$ . If there is voltage ( $V_{DISC\_DET\_FALL}$ ) on  $V_{OUT}$ , the discharge circuit will discharge the  $V_{IN}$  to below 0.8 V. If the voltage on  $V_{OUT}$  is less than  $V_{UVLO}$ , the discharge circuit will be turned off when  $V_{IN}$  falls below  $V_{UVLO}$ . There is also a watchdog timer that will turn off the discharge if the discharge circuit cannot discharge the  $V_{IN}$  down to  $V_{DISC\_MIN}$  within  $t_{DISC\_TIMEOUT}$ .

## In-rush Current Limit and SCP at Start Up

AOZ1390DI has the current limit and short circuit protection functions at start up. The current limit is a function of voltage drop from  $V_{IN}$  to  $V_{OUT}$ . The limit will increase if the ( $V_{IN} - V_{OUT}$ ) voltage decreases. With this current limit control, the inrush current can be effectively clamped to reduce the initial current spikes. At initial startup, the internal power switch carries large voltage close to  $V_{IN}$  and has large power loss. To ensure the internal MOSFET working in Safe Operation Area (SOA), a fixed timer is set to shut down the power switch if the inrush current is clamped by current limit ramp for about 512  $\mu\text{s}$  continuously. This timer will be reset once the inrush current drops below the current limit. For short circuit event, the part will shut down after this 512  $\mu\text{s}$  timer is finished. In case of large output capacitors, the soft start time needs to increase to avoid the large inrush current hit the current limit for 512  $\mu\text{s}$ . SCP is not active after the soft start is completed.

**AOZ1390DI-01 (Auto-Restart version):** The power switch is turned off under SCP condition at startup. The device will try to restart indefinitely for every 64 ms ( $t_{SCP\_REC\_01}$ ) until it is disabled.

**AOZ1390DI-02 (Latch-Off version):** The power switch is turned off under SCP condition at startup. The device will try to restart 4 time with 2 ms ( $t_{SCP\_REC\_02}$ ) blanking time. If SCP condition still exist after this 4 retries, the device will be latched off. After latch-off, either toggling the EN input logic to reset the device or cycling the input voltage can turn on the power switch.

## Fault Protection

The AOZ1390DI offers protection against the following fault conditions:  $V_{IN}$  over voltage (OVP),  $V_{OUT}$  greater than  $V_{IN}$  (TRCB), and over temperature (OTP).

When the device is first enabled, the power switch is off and fault conditions are checked. If  $V_{IN}$  is higher than the OVP threshold, or SCP during start up or the die temperature is higher than thermal shutdown threshold, the FLTB pin will be pulled low to flag the fault.

After the power switch turns on, the device continuously monitors all fault conditions. The switch is immediately turned off when over voltage,  $V_{OUT}$  greater than  $V_{IN}$  or over temperature is detected. FLTB pin will be subsequently pulled low at OVP or TSD condition.

**Table 1. AOZ1390DI-01 Fault flag response to all protection functions**

Protection	Fault Response	FLTB Status
IDTRCB	Auto-restart without soft-start at fault removal	High Impedance
Startup SCP	Auto-restart after 64ms	Low
TSD	Auto-restart with soft-start at 64ms after fault removal	Low
OVP	Auto-restart with soft-start at 64ms after fault removal	Low

**Table 2. AOZ1390DI-02 Fault flag response to all protection functions**

Protection	Fault Response	FLTB Status
IDTRCB	Auto-restart without soft-start at fault removal	High Impedance
Startup SCP	4 times retry then latch-off	Low
TSD	Latch-off	Low
OVP	Latch-off	Low

## Slow Turn Off

Slow turn off reduces the voltage spikes that can arise if the switch is turned off too quickly. The device current is ramped down to 0 A in 32  $\mu\text{s}$  after the EN is de-asserted to reduce these voltage spikes.

### Limited Power Source (LPS) Protection

When the device is disable (EN = 0 V), it continuously monitors the VIN voltage. If VIN exceeds LPSB detection threshold ( $V_{LPSB\_VIN\_DET}$ ) for more than 2.5 s, the LPSB pin is pulled low to indicate a possible short across the power switch as shown in Figure 13. LPSB is an open drain output and an external pull up is required under no fault condition.

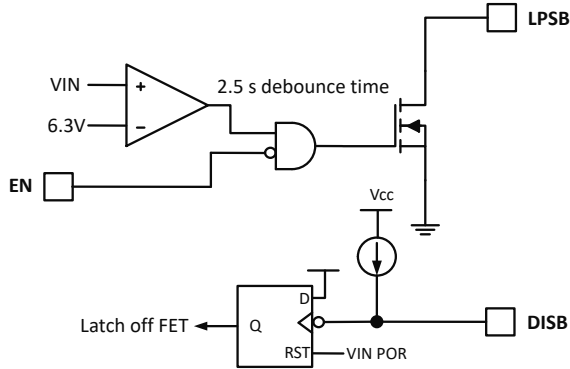

Figure 13. LPSB pulls low when VIN > 6.3 V and part is disabled

For multi-port ORing or parallel power applications, the LPSB pin of a AOZ1390DI device can be connected to DISB pin of one or more AOZ1390DI devices at other ports as shown in Figure 14. This configuration will turn off all connected devices regardless of the status of their EN pins. When all devices are off, the shared power bus at VOUT will not be energized. Thus, no excessive power will flow from VOUT bus to the port of the shorted power switch.

The LPSB is cleared when VIN drops below LPSB detection lower threshold voltage ( $V_{LPSB\_VIN\_DET} - V_{LPSB\_VIN\_HYS}$ ) or the device is enabled. However, DISB going high does not enable the connected AOZ1390DI. The device can only be turned on by cycling VIN power. Please refer the Figure 3 for timing details.

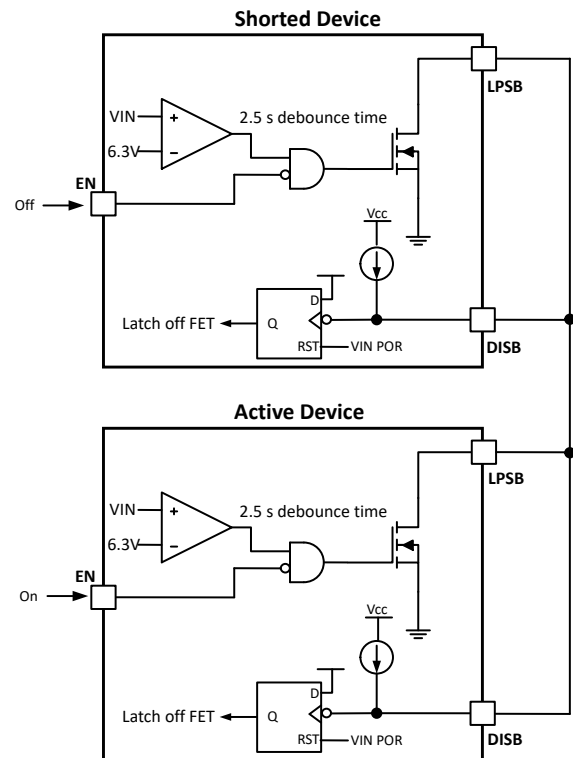

Figure 14. Connected LPSB and DISB of all devices to protect excessive power through shorted device.

### Input Capacitor Selection

The input capacitor prevents large voltage transients from appearing at the input, and provides the instantaneous current needed each time the switch turns on to charge output capacitors and to limit input voltage drop. It is also to prevent high-frequency noise on the power line from passing through to the output. The input capacitor should be located as close to the pin as possible. A 10  $\mu$ F ceramic capacitor is recommended. For Type-C port application, the USB specification limits the capacitance on VBUS (VIN) to a maximum of 10 $\mu$ F. Use this maximum value for noise immunity due to the system and cable plug/unplug transients.

## Layout Guidelines

The exposed thermal pad transfers heat from the AOZ1390DI to the PCB. It is the common drain node of the power switch and no electrical connection is allowed. In order to transfer heat from the device as quick as possible, put a thermal copper pad directly beneath the exposed pad. Make the pad as large as the exposed pad. Extend out the top of the device for better heat sinking capability. For more effective heat sinking, attach the exposed pad to as many layers as possible (inner layers and the back side of the PCB). Each inner layer must be an island with no electrical connection to any other signals or power. Place the maximum number of VIAs as allowed within the exposed pad area.

The output and input capacitors ( $C_{OUT}$  and  $C_{IN}$ ) should be placed as close as possible to their respective pins (VOUT and VIN). This reduces transient under/overshoots due to load or line transients to a minimum.

A TVS diode should be placed as close to the device as possible and next to the input capacitor. The large plane should be used to connect the VIN, VOUT and GND. Make this plane broad and continuous (no cut or breaks) to eliminate ground loop noise and reduce transient under and overshoots. The device ground pin (pin 7), the  $C_{OUT}$ , and the  $C_{IN}$  ground connections should connect directly to the ground plane. Do not route through any narrow traces before connecting to the ground plane main body.

## Power Dissipation Calculation

Calculate the power dissipation for normal load condition using the following equation:

For  $I_{OUT} < 2.5$  A (Ideal Diode mode):

$$Power\ Dissipated = V_{IDEAL\ DIODE\ DROP} \times I_{OUT}$$

For  $I_{OUT} > 2.5$  A (Enhanced mode: MOSFET fully on):

$$Power\ Dissipated = R_{ON} \times I_{OUT}^2$$



Package Dimensions, DFN3.5x3-14L

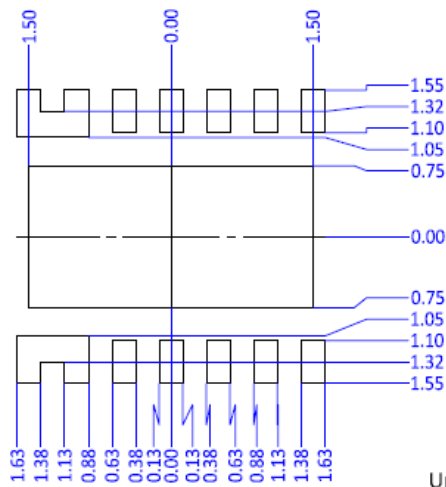
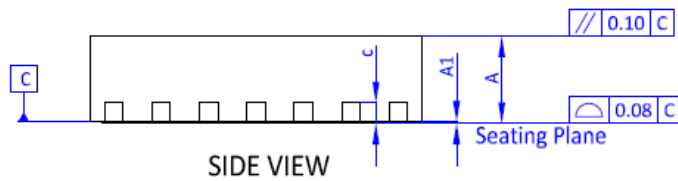
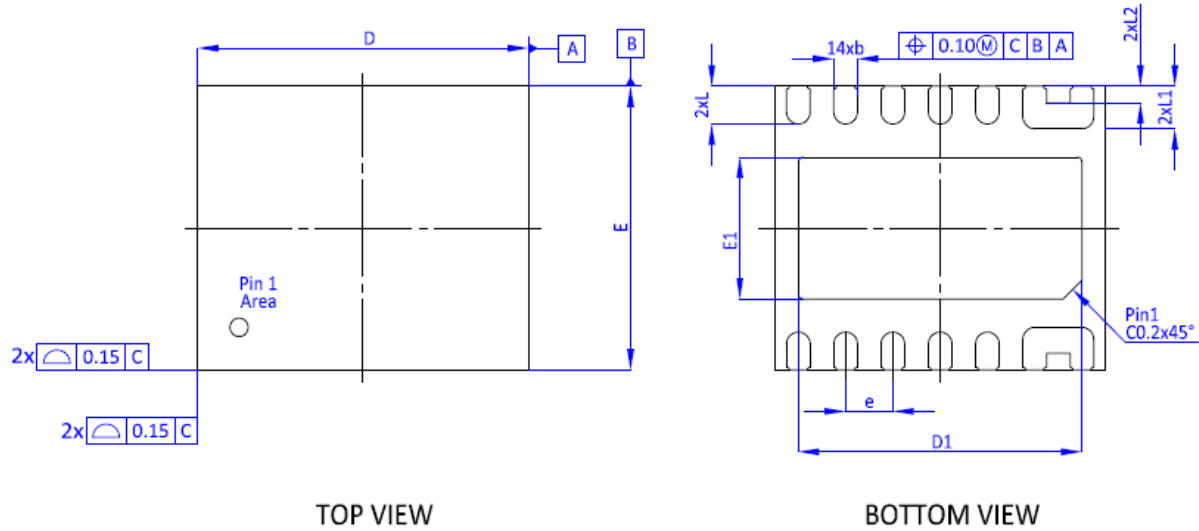

Unit: mm

RECOMMENDED LAND PATTERN

SYMBOLS	DIM. IN MM			DIM. IN INCH		
	MIN.	NOM.	MAX.	MIN.	NOM.	MAX.
A	0.80	0.90	1.00	0.031	0.035	0.039
A1	0.00	---	0.05	0.000	---	0.002
D	3.40	3.50	3.60	0.134	0.138	0.142
D1	2.90	3.00	3.10	0.114	0.118	0.122
E	2.90	3.00	3.10	0.114	0.118	0.122
E1	1.40	1.50	1.60	0.055	0.059	0.063
L	0.30	0.40	0.50	0.012	0.016	0.020
L1	0.35	0.45	0.55	0.014	0.018	0.022
L2	0.08	0.18	0.28	0.003	0.007	0.011
b	0.18	0.25	0.30	0.007	0.010	0.012
c	0.20			0.008		
e	0.50 BSC			0.020 BSC		

NOTE:

1. Dimensioning and tolerancing comply with ASME Y14.5M 1994.
2. Controlled dimensions are in millimeters.
3. Coplanarity applies to the exposed pad(s) and all terminal leads having metallization.

Package Dimensions, DFN3.5x3-14L

DFN3.5x3 14L EP1 S Carrier Tape

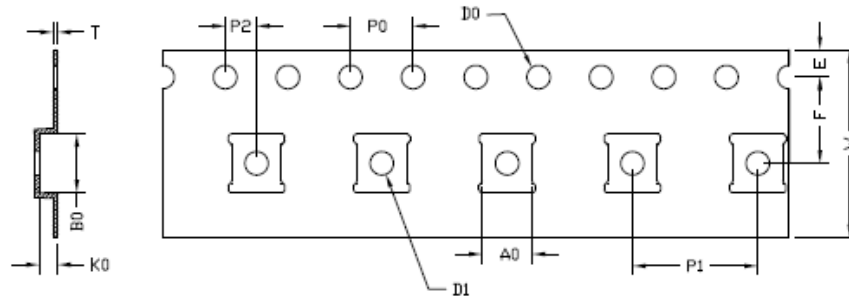

UNIT: MM

PACKAGE	A0	B0	K0	D0	D1	W	E	F	P0	P1	P2	T
DFN3.5x3 (12 mm)	3.20 ±0.05	3.75 ±0.05	1.20 ±0.05	1.50 $\begin{smallmatrix} +0.10 \\ -0.10 \end{smallmatrix}$	1.50 $\begin{smallmatrix} +0.10 \\ -0.10 \end{smallmatrix}$	12.00 $\begin{smallmatrix} +0.30 \\ -0.30 \end{smallmatrix}$	1.75 ±0.10	5.50 ±0.05	4.00 ±0.10	8.00 ±0.10	2.00 ±0.05	0.30 ±0.03

DFN3.5x3 14L EP1 S Reel

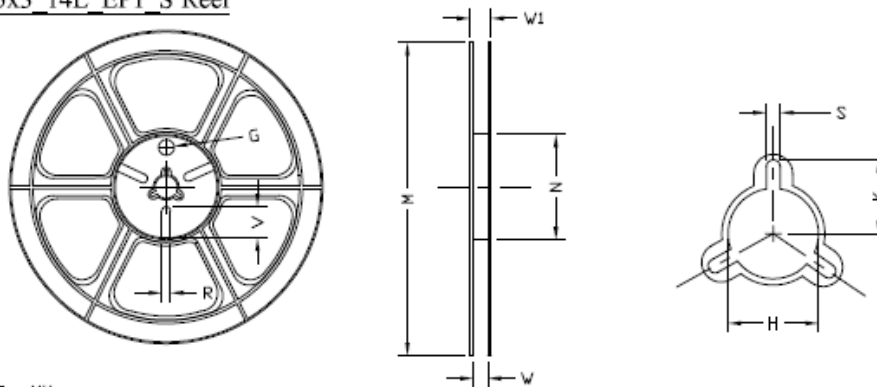

UNIT: MM

TAPE SIZE	REEL SIZE	M	N	W	W1	H	K	S	G	R	V
12 mm	φ330	φ330.00 ±0.50	φ97.00 ±0.10	13.00 ±0.30	17.40 ±1.00	φ13.00 $\begin{smallmatrix} +0.50 \\ -0.20 \end{smallmatrix}$	10.60	2.00 ±0.50	---	---	---

DFN3.5x3 14L EP1 S Tape

Leader / Trailer  
& Orientation

Unit Per Reel:  
3000pcs

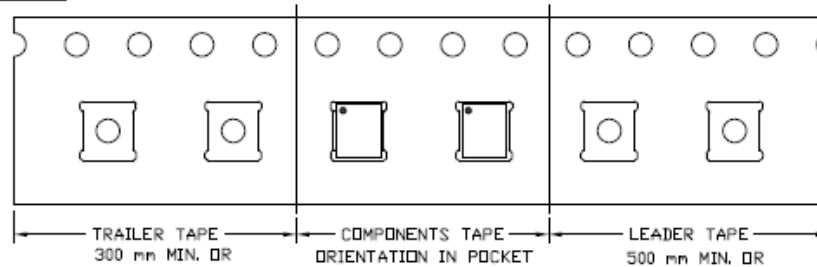

## Part Marking

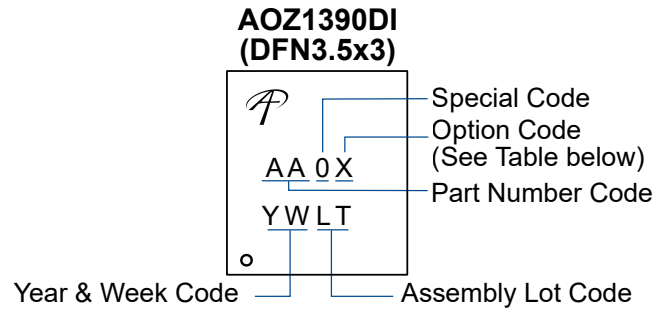

Part Number	Description	Marking Code
AOZ1390DI-01	Green Product	AA01
AOZ1390DI-02	Green Product	AA02

### LEGAL DISCLAIMER

Applications or uses as critical components in life support devices or systems are not authorized. Alpha and Omega Semiconductor does not assume any liability arising out of such applications or uses of its products. AOS reserves the right to make changes to product specifications without notice. It is the responsibility of the customer to evaluate suitability of the product for their intended application. Customer shall comply with applicable legal requirements, including all applicable export control rules, regulations and limitations.

AOS's products are provided subject to AOS's terms and conditions of sale which are set forth at:

[http://www.aosmd.com/terms\\_and\\_conditions\\_of\\_sale](http://www.aosmd.com/terms_and_conditions_of_sale)

### LIFE SUPPORT POLICY

ALPHA AND OMEGA SEMICONDUCTOR PRODUCTS ARE NOT AUTHORIZED FOR USE AS CRITICAL COMPONENTS IN LIFE SUPPORT DEVICES OR SYSTEMS.

As used herein:

1. Life support devices or systems are devices or systems which, (a) are intended for surgical implant into the body or (b) support or sustain life, and (c) whose failure to perform when properly used in accordance with instructions for use provided in the labeling, can be reasonably expected to result in a significant injury of the user.
2. A critical component in any component of a life support device, or system whose failure to perform can be reasonably expected to cause the failure of the life support device or system, or to affect its safety or effectiveness.