

QFN3x3_21L_EP2_S PACKAGE OUTLINE

PIN 1 DOT BY MARKING

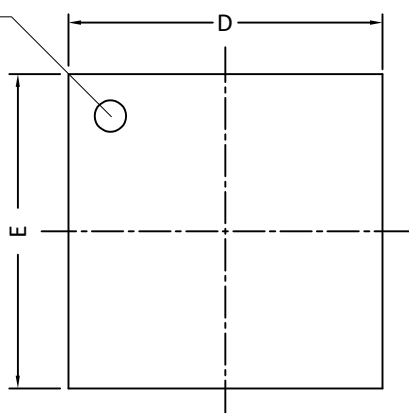

TOP VIEW

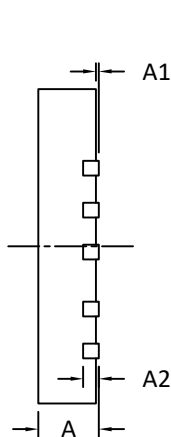

SIDE VIEW

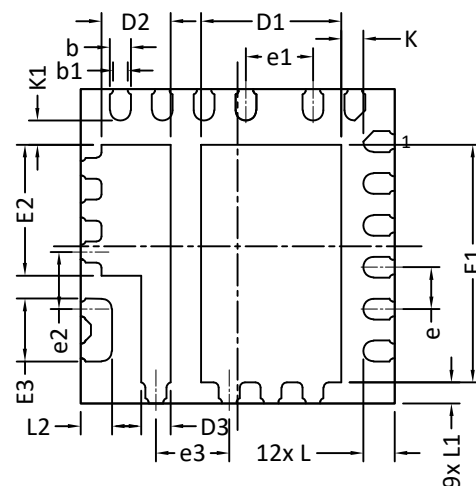

BOTTOM VIEW

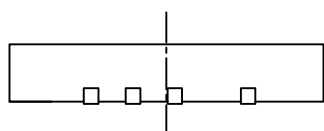

SIDE VIEW

RECOMMENDED LAND PATTERN

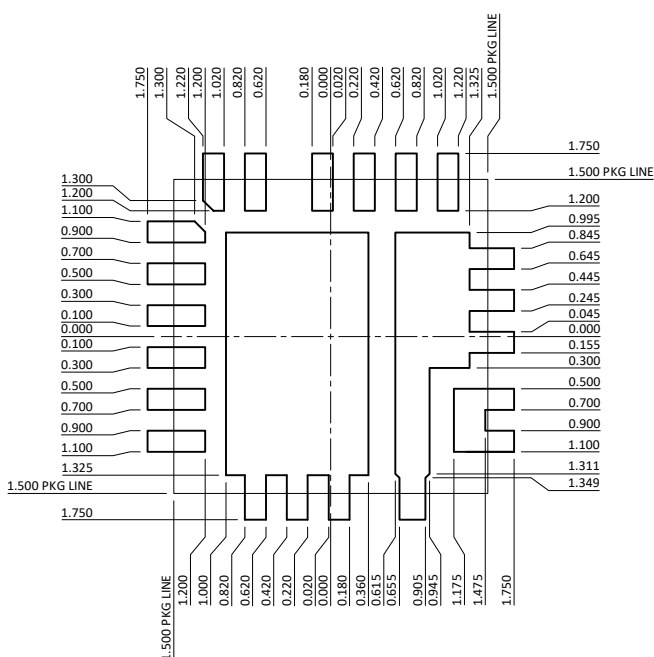

SYMBOLS	DIM. IN MM			DIM. IN INCH		
	MIN.	NOM.	MAX.	MIN.	NOM.	MAX.
A	0.50	0.55	0.60	0.020	0.022	0.024
A1	0.00	---	0.05	0.000	---	0.002
A2	0.152 REF.			0.006 REF.		
D	2.90	3.00	3.10	0.114	0.118	0.122
D1	1.24	1.34	1.44	0.049	0.053	0.057
D2	0.56	0.66	0.76	0.022	0.026	0.030
D3	0.18	0.28	0.38	0.007	0.011	0.015
E	2.90	3.00	3.10	0.114	0.118	0.122
E1	2.17	2.27	2.37	0.085	0.089	0.093
E2	1.15	1.25	1.35	0.045	0.049	0.053
E3	0.50	0.60	0.70	0.020	0.024	0.028
L	0.25	0.30	0.35	0.010	0.012	0.014
L1	0.15	0.20	0.25	0.006	0.008	0.010
L2	0.25	0.30	0.35	0.010	0.012	0.014
K	0.21 REF.			0.008 REF.		
K1	0.23 REF.			0.009 REF.		
b	0.15	0.20	0.25	0.006	0.008	0.010
b1	0.09	0.14	0.19	0.004	0.006	0.007
e	0.40 BSC			0.016 BSC		
e1	0.64 BSC			0.025 BSC		
e2	0.545 BSC			0.021 BSC		
e3	0.70 BSC			0.028 BSC		

Note:

- CONTROLLING DIMENSION IS MILLIMETER.
CONVERTED INCH DIMENSIONS ARE NOT NECESSARILY EXACT.