

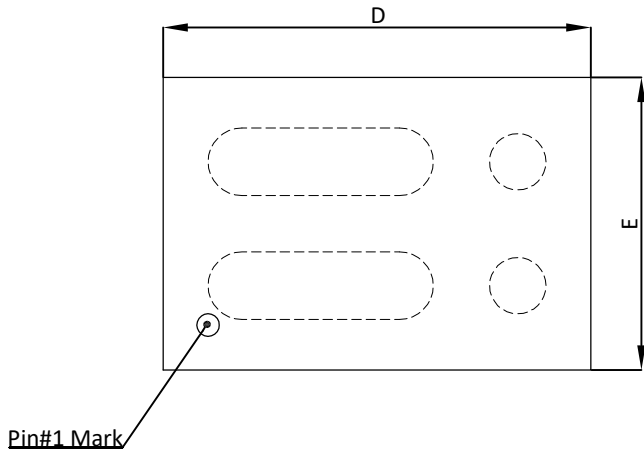

AlphaDFN1.90x1.30A_4 PACKAGE OUTLINE

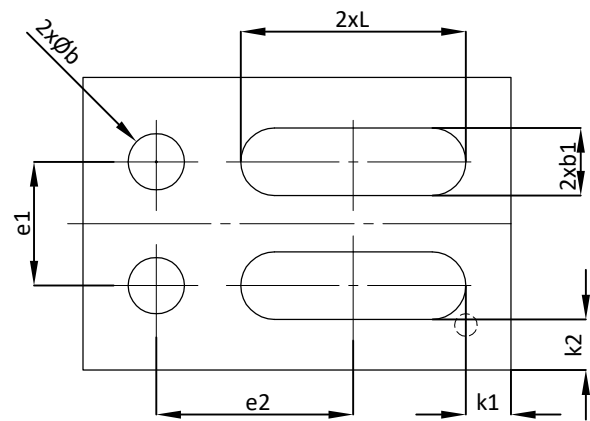

TOP VIEW



BOTTOM VIEW

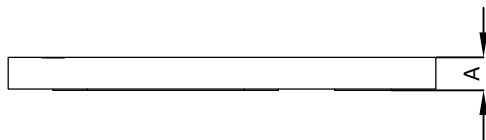

SIDE VIEW

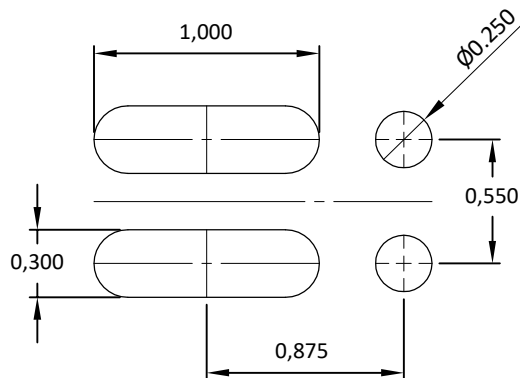

RECOMMENDED LAND PATTERN

SYMBOLS	DIM. IN MM			DIM. IN INCH		
	MIN.	NOM.	MAX.	MIN.	NOM.	MAX.
A	0.117	0.147	0.177	0.0046	0.0058	0.0070
D	1.870	1.900	1.930	0.0736	0.0748	0.0760
E	1.270	1.300	1.330	0.0500	0.0512	0.0524
b	0.220	0.250	0.280	0.0087	0.0098	0.0110
b1	0.270	0.300	0.330	0.0106	0.0118	0.0130
e1	0.550BSC.			0.0217BSC.		
e2	0.875BSC.			0.0344BSC.		
L	0.970	1.000	1.030	0.0382	0.0394	0.0406
k1	---	0.200	---	---	0.0079	---
K2	---	0.225	---	---	0.0089	---

NOTE:

1. CONTROLLED DIMENSIONS ARE IN MILLIMETERS.
2. TOP VIEW IS THE VIEW OF TOP SURFACE OF THE PART HAVING INDEX AND PART NUMBER MARKING.
3. THIS PACKAGE WAS QUALIFIED USING IR REFLOW PROCESS (JEDEC STANDARD). FOR USAGE IN OTHER SOLDERING PROCESSES, PLEASE CONTACT LOCAL AOS REPRESENTATIVES.