

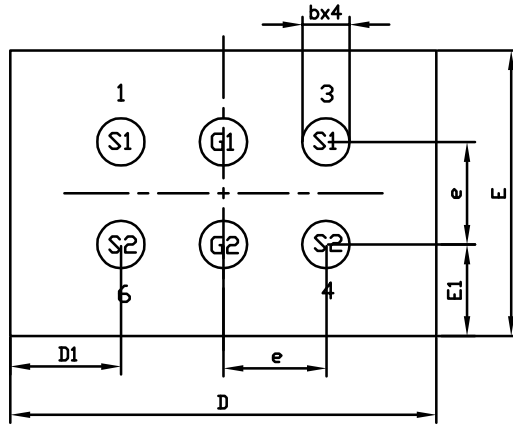

AlphaDFN2.7x1.81_6 PACKAGE OUTLINE

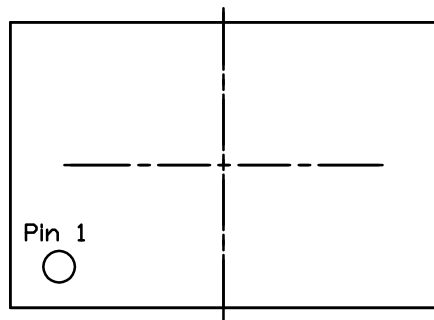

BUMP UP

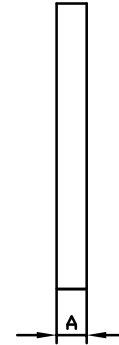

BUMP DOWN

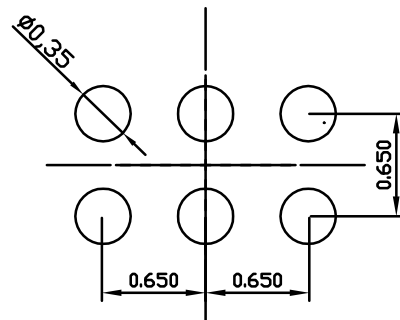

RECOMMENDED LAND PATTERN

SYMBOLS	DIMENSIONS IN MILLIMETERS			DIMENSIONS IN INCHES		
	MIN	NOM	MAX	MIN	NOM	MAX
A	0.130	0.190	0.250	0.0051	0.0075	0.0098
b	0.250	0.300	0.350	0.0098	0.0118	0.0138
D	2.650	2.700	2.750	0.1043	0.1063	0.1083
D1	0.650	0.700	0.750	0.0256	0.0276	0.0295
E	1.750	1.800	1.850	0.0689	0.0709	0.0728
E1	0.525	0.575	0.625	0.0207	0.0226	0.0246
e	0.650 BSC			0.0256 BSC		

NOTE:

1. CONTROLLED DIMENSIONS ARE IN MILLIMETERS. CONVERTED INCH DIMENSIONS ARE NOT NECESSARILY EXACT.
2. THE SCRIBLE LINE IS NOT INCLUDED IN THE POD, IF WITH SCRIBLE LINE, D AND E DIMENSION WILL PLUS 0.05MM RESPECTIVELY.