

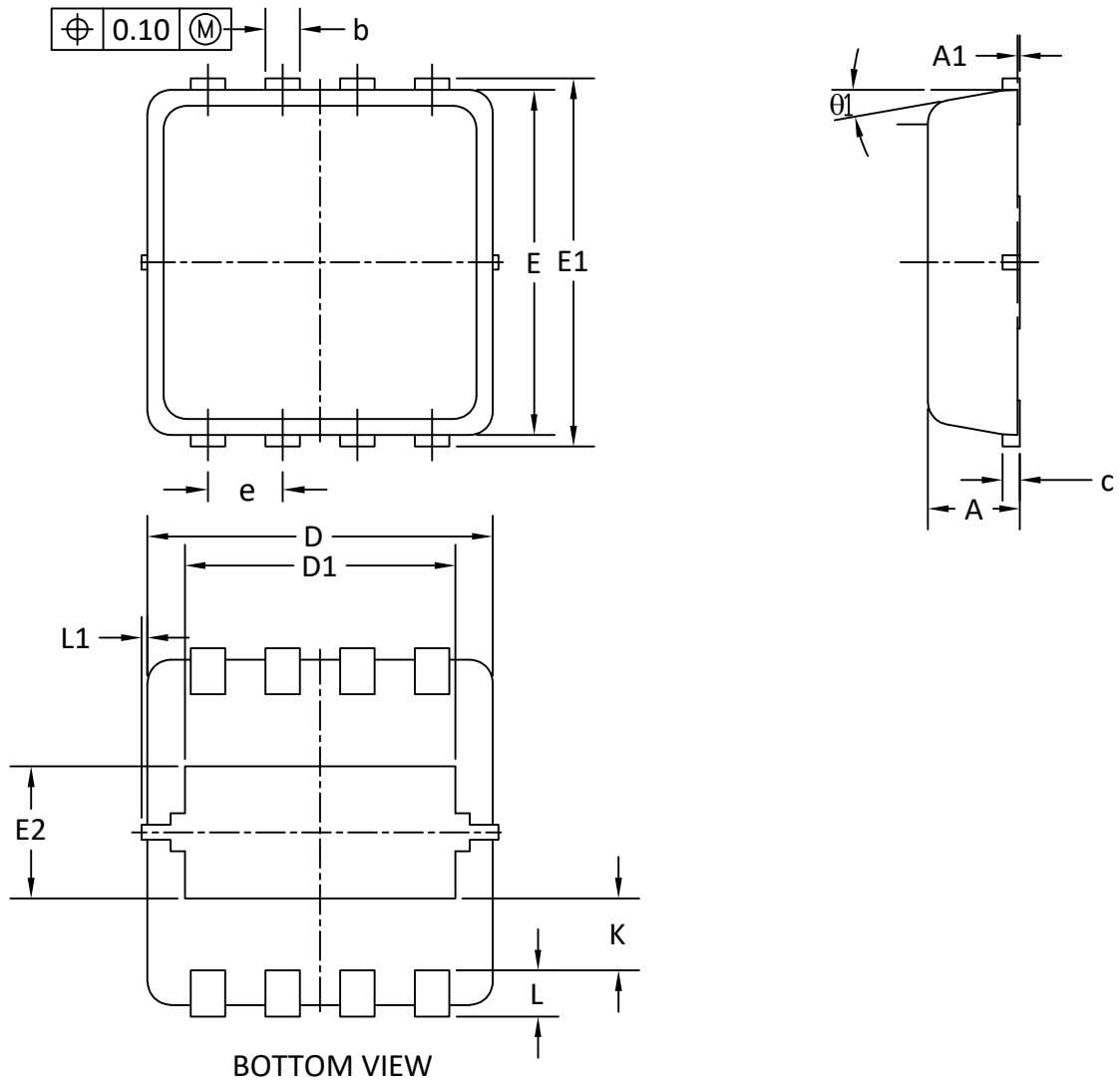

DFN3x3B_8L_EP1_P PACKAGE OUTLINE



BOTTOM VIEW

RECOMMENDED LAND PATTERN

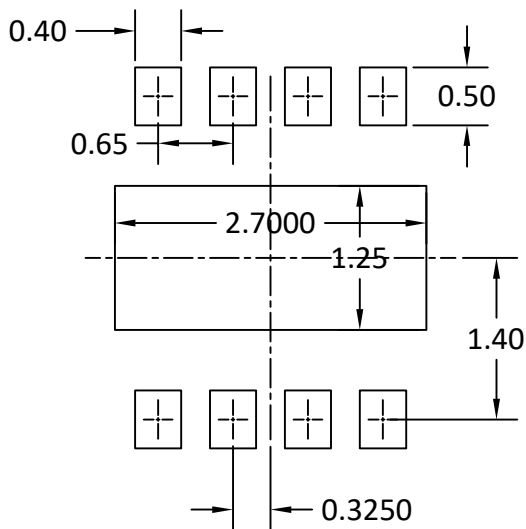

SYMBOLS	DIM. IN MM			DIM. IN INCH		
	MIN.	NOM.	MAX.	MIN.	NOM.	MAX.
A	0.700	0.800	0.900	0.028	0.031	0.035
A1	0.000	-	0.050	0.000	-	0.002
b	0.240	0.300	0.350	0.009	0.012	0.014
c	0.100	0.150	0.250	0.004	0.006	0.010
D	2.900	3.000	3.100	0.114	0.118	0.122
D1	2.150	2.350	2.550	0.085	0.093	0.100
E	2.900	3.000	3.100	0.114	0.118	0.122
E1	3.050	3.200	3.350	0.120	0.126	0.132
E2	1.100	1.150	1.200	0.043	0.045	0.047
e	0.600	0.650	0.700	0.024	0.026	0.028
K	0.575	0.625	0.675	0.023	0.025	0.027
L	0.300	0.400	0.500	0.012	0.016	0.020
L1	0.000	-	0.100	0.000	-	0.004
theta1	0°	10°	12°	0°	10°	12°

NOTE

1. PACKAGE BODY SIZES EXCLUDE MOLD FLASH AND GATE BURRS.
MOLD FLASH AT THE NON-LEAD SIDES SHOULD BE LESS THAN 6 MILS EACH.
2. CONTROLLING DIMENSION IS MILLIMETER.
CONVERTED INCH DIMENSIONS ARE NOT NECESSARILY EXACT.