

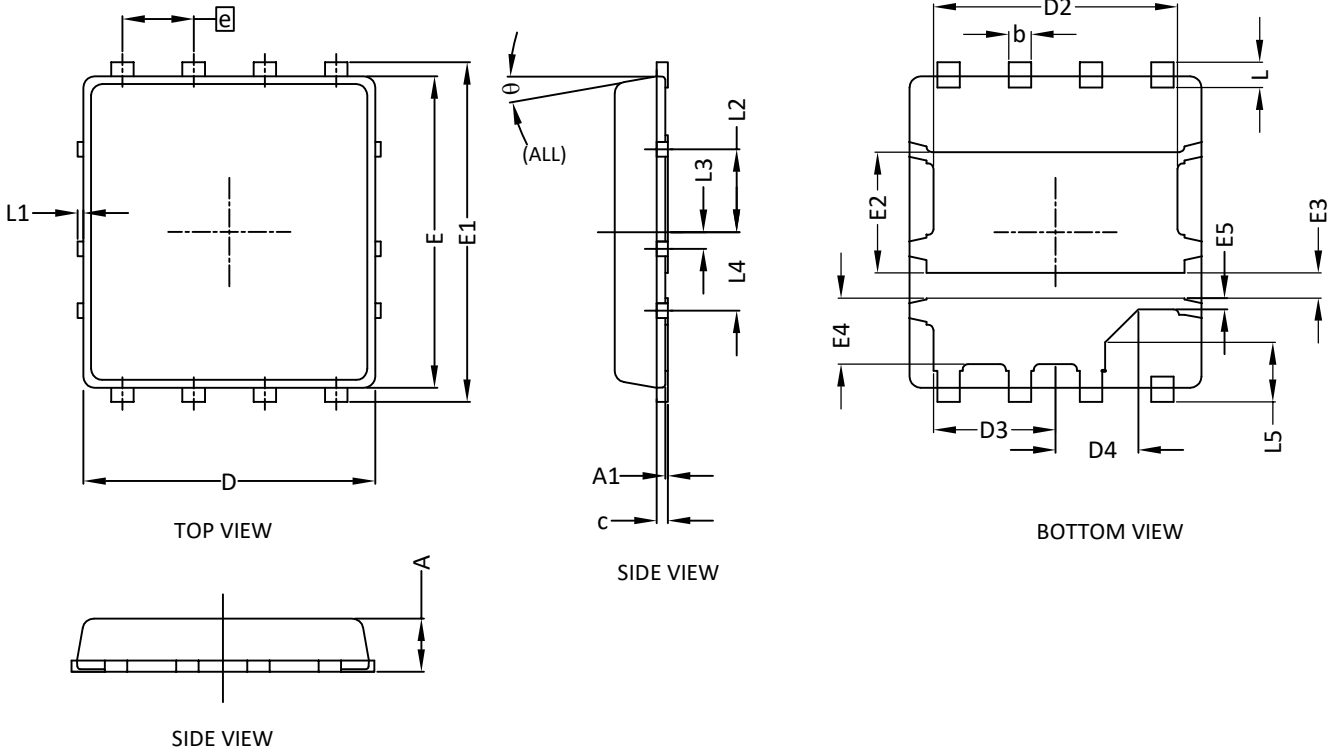

DFN5x6D\_8L\_EP2\_P PACKAGE OUTLINE

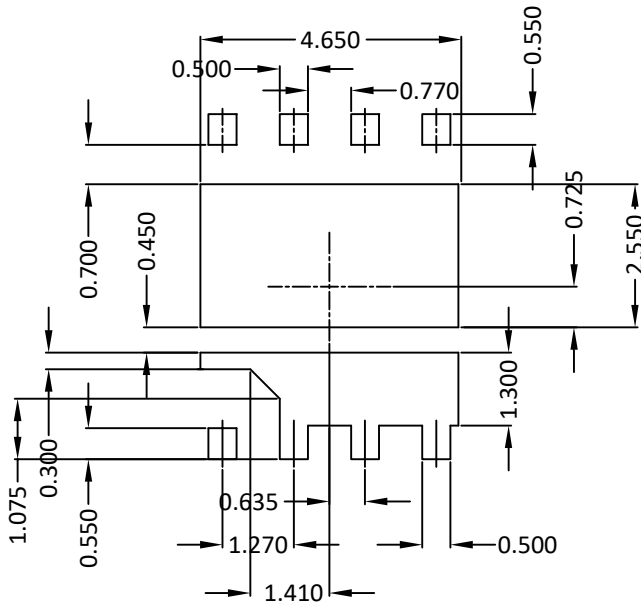

RECOMMENDED LAND PATTERN



UNIT: mm

SYMBOLS	DIMENSIONS IN MILLIMETERS			DIMENSIONS IN INCHES		
	MIN	NOM	MAX	MIN	NOM	MAX
A	0.85	0.90	1.00	0.033	0.035	0.039
A1	0.00	---	0.05	0.000	---	0.002
b	0.35	0.40	0.45	0.014	0.016	0.018
c	0.15	0.20	0.25	0.006	0.008	0.010
D	5.10	5.20	5.30	0.201	0.205	0.209
D2	4.20	4.35	4.50	0.165	0.171	0.177
D3	2.125	2.175	2.225	0.084	0.086	0.088
D4	1.376	1.476	1.576	0.0542	0.0582	0.0622
E	5.45	5.55	5.65	0.215	0.219	0.222
E1	5.95	6.05	6.15	0.234	0.238	0.242
E2	2.00	2.15	2.30	0.079	0.085	0.091
E3	0.35	0.45	0.55	0.014	0.018	0.022
E4	1.075	1.175	1.275	0.042	0.046	0.050
E5	0.150	0.200	0.250	0.006	0.008	0.010
e	1.27 BSC			0.050 BSC		
L	0.35	0.45	0.55	0.014	0.018	0.022
L1	0	---	0.10	0	---	0.004
L2	1.375	1.475	1.575	0.054	0.058	0.062
L3	0.20	0.30	0.40	0.008	0.012	0.016
L4	1.30	1.40	1.50	0.051	0.055	0.059
L5	0.960	1.060	1.160	0.038	0.042	0.046
θ	0°	---	10°	0°	---	10°

NOTE

- PACKAGE BODY SIZES EXCLUDE MOLD FLASH AND GATE BURRS. MOLD FLASH AT THE NON-LEAD SIDES SHOULD BE LESS THAN 6 MILS EACH.
- CONTROLLING DIMENSION IS MILLIMETER. CONVERTED INCH DIMENSIONS ARE NOT NECESSARILY EXACT.
- THIS PACKAGE WAS QUALIFIED USING IR REFLOW PROCESS (JEDEC STANDARD). FOR USAGE IN OTHER SOLDERING PROCESSES, PLEASE CONTACT LOCAL AOS REPRESENTATIVES.