

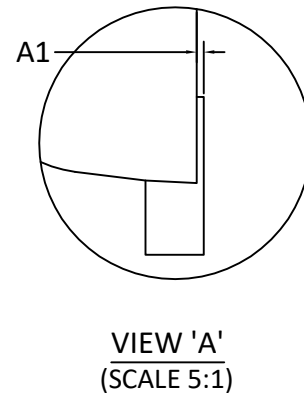

DFN5x6F_8L_EP1_P PACKAGE OUTLINE

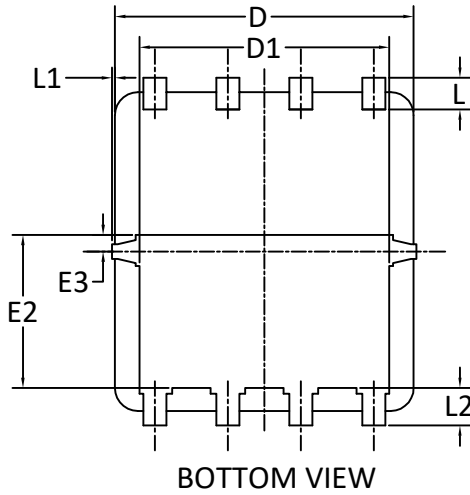

RECOMMENDED LAND PATTERN

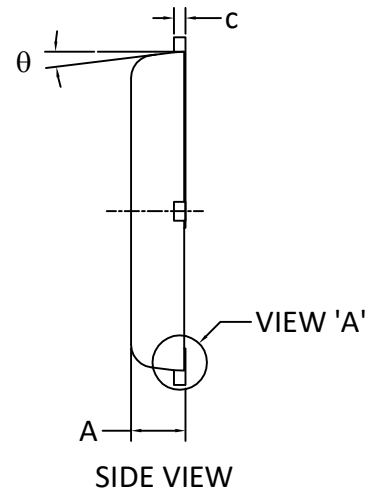
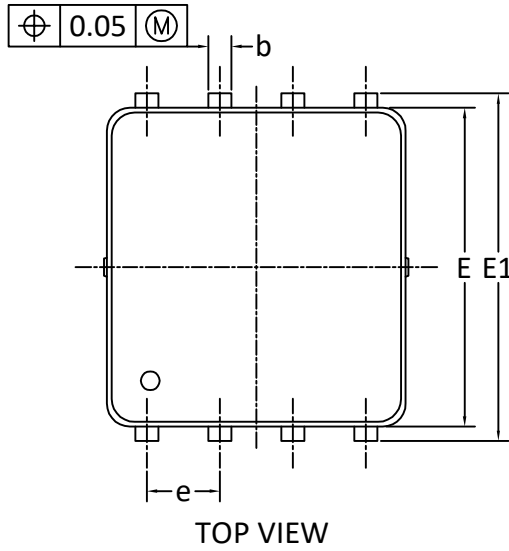
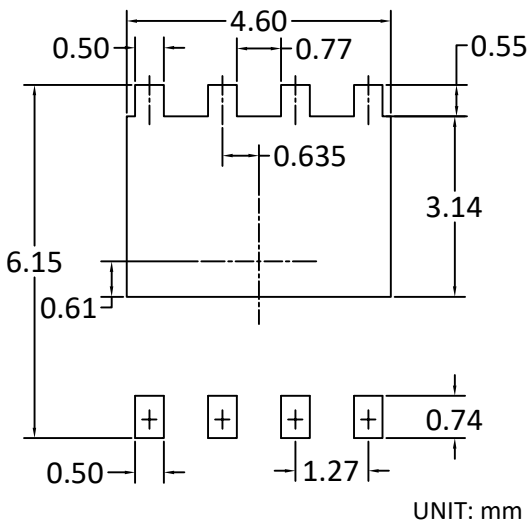

SYMBOLS	DIMENSION IN MM			DIMENSION IN INCHES		
	MIN	NOM	MAX	MIN	NOM	MAX
A	0.85	0.95	1.00	0.033	0.037	0.039
A1	0.00	---	0.05	0.000	----	0.002
b	0.30	0.40	0.50	0.012	0.016	0.020
c	0.15	0.20	0.25	0.006	0.008	0.010
D	5.10	5.20	5.30	0.201	0.205	0.209
D1	4.25	4.35	4.45	0.167	0.171	0.175
E	5.45	5.55	5.65	0.215	0.219	0.222
E1	5.95	6.05	6.15	0.234	0.238	0.242
E2	2.57	2.67	2.77	0.101	0.105	0.109
E3	0.19	0.29	0.39	0.007	0.011	0.015
e	1.27 BSC			0.050 BSC		
L	0.45	0.55	0.65	0.018	0.022	0.026
L1	0.00	---	0.15	0.000	----	0.006
L2	0.65 REF			0.026 REF		
θ	0°	---	10°	0°	----	10°

NOTE:

1. PACKAGE BODY SIZES EXCLUDE MOLD FLASH AND GATE BURRS.
MOLD FLASH AT THE NON-LEAD SIDES SHOULD BE LESS THAN 6 MILS EACH.
2. CONTROLLING DIMENSION IS MILLIMETER.
3. THIS PACKAGE WAS QUALIFIED USING IR REFLOW PROCESS (JEDEC STANDARD). FOR USAGE IN OTHER SOLDERING PROCESSES, PLEASE CONTACT LOCAL AOS REPRESENTATIVES.