

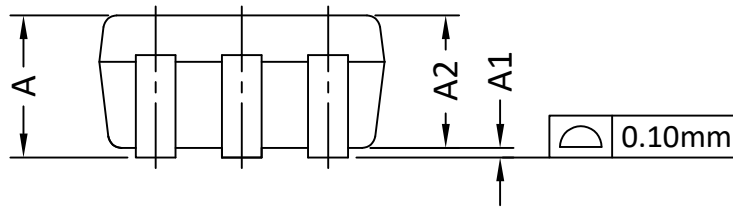

SC70_6L PACKAGE OUTLINE

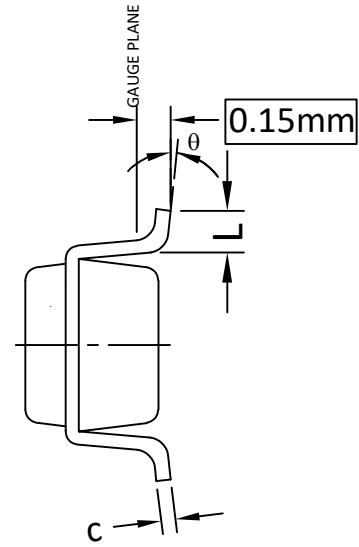

RECOMMENDED LAND PATTERN

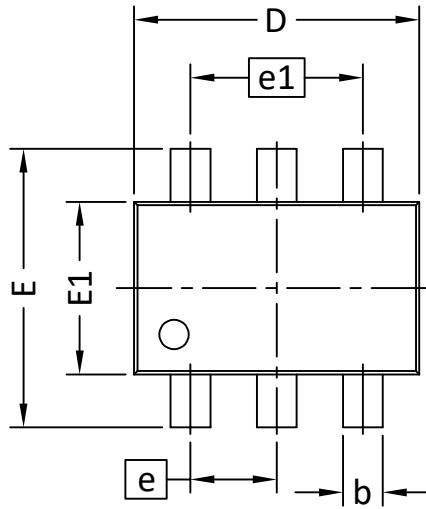
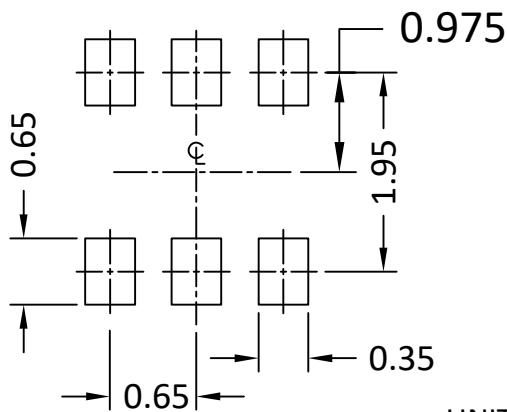

UNIT: mm

SYMBOLS	DIM. IN MM			DIM. IN INCH		
	MIN.	NOM.	MAX.	MIN.	NOM.	MAX.
A		-----	1.10		-----	0.043
A1	0.000	-----	0.10	0.000	-----	0.004
A2	0.700	0.900	1.00	0.028	0.035	0.039
b	0.150	-----	0.300	0.006	-----	0.012
c	0.080	-----	0.220	0.003	-----	0.009
D	1.850	2.100	2.150	0.073	0.083	0.085
E	1.800	2.300	2.400	0.071	0.091	0.094
e	0.65BSC			0.026BSC		
e1	1.30BSC			0.051BSC		
E1	1.100	1.300	1.400	0.043	0.051	0.055
L	0.260	0.360	0.460	0.010	0.014	0.018
θ	0°	4°	8°	0°	4°	8°

NOTE

1. ALL DIMENSIONS ARE IN MILLIMETERS.
2. DIMENSIONS ARE INCLUSIVE OF PLATING.
3. PACKAGE BODY SIZES EXCLUDE MOLD FLASH AND GATE BURRS.
MOLD FLASH AT THE NON-LEAD SIDES SHOULD BE LESS THAN 3 MILS EACH.
4. DIE IS FACING UP FOR MOLD AND FACING DOWN FOR TRIM/FORM.
ie:REVERSE TRIM/FORM.
5. DIMENSION L IS MEASURED IN GAUGE PLANE.
6. CONTROLLING DIMENSION IS MILLIMETER.
CONVERTED INCH DIMENSIONS ARE NOT NECESSARILY EXACT.