

General Description

The AOZ71031QI is a high performance digital and analog hybrid multiphase buck controller designed in compliance with Intel IMVP8, 9, and 9.1/9.2 platform specifications. It provides three output rails (up to 9+1+1) and supports 4 separate SVID domains. Up to 9 phases for core voltage domain (IA), 1 phase for graphics voltage domain (GT) and 1 phase for Auxiliary domain (SA) as well as the P_{sys} domain's reporting functions, incorporated into a single SVID interface. AOS offers a novel AOS Advanced Transient Modulator (A²TM). It combines an advanced variable frequency hysteretic peak current mode control with proprietary phase current sensing scheme for fast transient response and low system cost. The control loop enhances light-load efficiency by seamlessly entering DCM mode of operation. Autonomous Phase Management also assures the optimized efficiency and power loss during light load with single phase DCM mode.

The AOZ71031QI is equipped with SMBus digital interface enabling register programming for tuning and configuration to minimize the system components and eliminate the need for manual solder rework on system board. Programmability can be done either by AOS GUI or customized ECS into the controller's built-in RAM or MTP. The controller provides MTP to store register settings once the configuration is finalized and the configuration can be updated more than ten times. In the production stage, the external resistor can be used for pin strap to choose 1 out of 6 config settings pre-programmed into the parts to achieve easy BOM management and minimize the number of PN and SKU.

Combined with AOS high performance DrMOS, the AOZ71031QI provides a complete power solution for Intel IMVP9.1/9.2 Meteor Lake S and Graphic card low power SKU applications. AOZ71031QI comes in a 7mm x 7mm 60-pin QFN package.

The AOZ71031QI controller features very low power consumption while still enabling digital interface control. This unique "Hybrid Digital" control scheme enables low quiescent power consumption in all power states as defined by the Intel IMVP9.1/9.2 platform to enable long system run times in battery life workloads.

The AOZ71031QI provides complete protection and warning functions including UVP, OVP, OCP, and OTP. Fault protection behavior can be easily programmed through SMBus. AOZ71031QI also offers real time telemetry information via SMBus for V_{IN}, V_{OUT}, temperature, output currents, power states, as well as P_{sys}/V_{sys}/IAUX pins reporting via SMBus.

Figure 1 shows the typical application implementation of the AOZ71031QI device in a multiphase buck VR.

Features

- 5.2V to 24V V_{IN} input supply voltage
- Triple output rails: 9/8/7/6/5/4/3/2/1 + 1 + 1
- Meteor Lake S and Graphic Platform
- Support Discrete Inductor and 2-phase Coupled L
- Autonomous Phase Management including phase shedding and auto DCM to optimize power loss
- Digital & analog hybrid controller with SMBus programmability and lowest power consumption
- SVID Interface to CPU/GPU compliant with IMVP8, 9, 9.1 and the latest 9.2 specifications
 - Support Fast V-Mode (FVM) to protect CPU
- Differential remote sensing to achieve 0.5% regulated V_{OUT} accuracy
- Low quiescent current: 4mA at PS0 for 9+1 configuration
- Supports multi-sourced industry standard DrMOS or SPS power stages
- User friendly GUI for compensation and configurations with minimal external RC components.
- ECS programmability for configurations with Built-in MTP and RAM with more than 10 times configuration changes
- Pin Strap for easy configuration with 6 configuration setting with same PN to minimize number of SKU
- Proprietary, high performance Adaptive Transient On-Proprietary, high performance AOS Advanced Transient Modulator (A²TM) control scheme:
 - Variable frequency hysteretic peak current mode control gives fast transient response
 - Dynamic phase current balance
 - Excellent load-line control and phase current sensing
 - Seamless CCM to DCM control to maximize efficiency
- System Input Power Monitoring (both P_{sys} and V_{sys})
- 300kHz to 1.8MHz programmable switching frequency
- Acoustic Noise Suppression
- Output Under-Voltage Protection (UVP)
- Output Over-Voltage Protection (OVP)
- Over-Current Protection (OCP)
- Over-Temperature Protection (OTP)
- QFN7x7-60L package

Applications

- Desktop computers
- Intel graphic cards



Typical Application

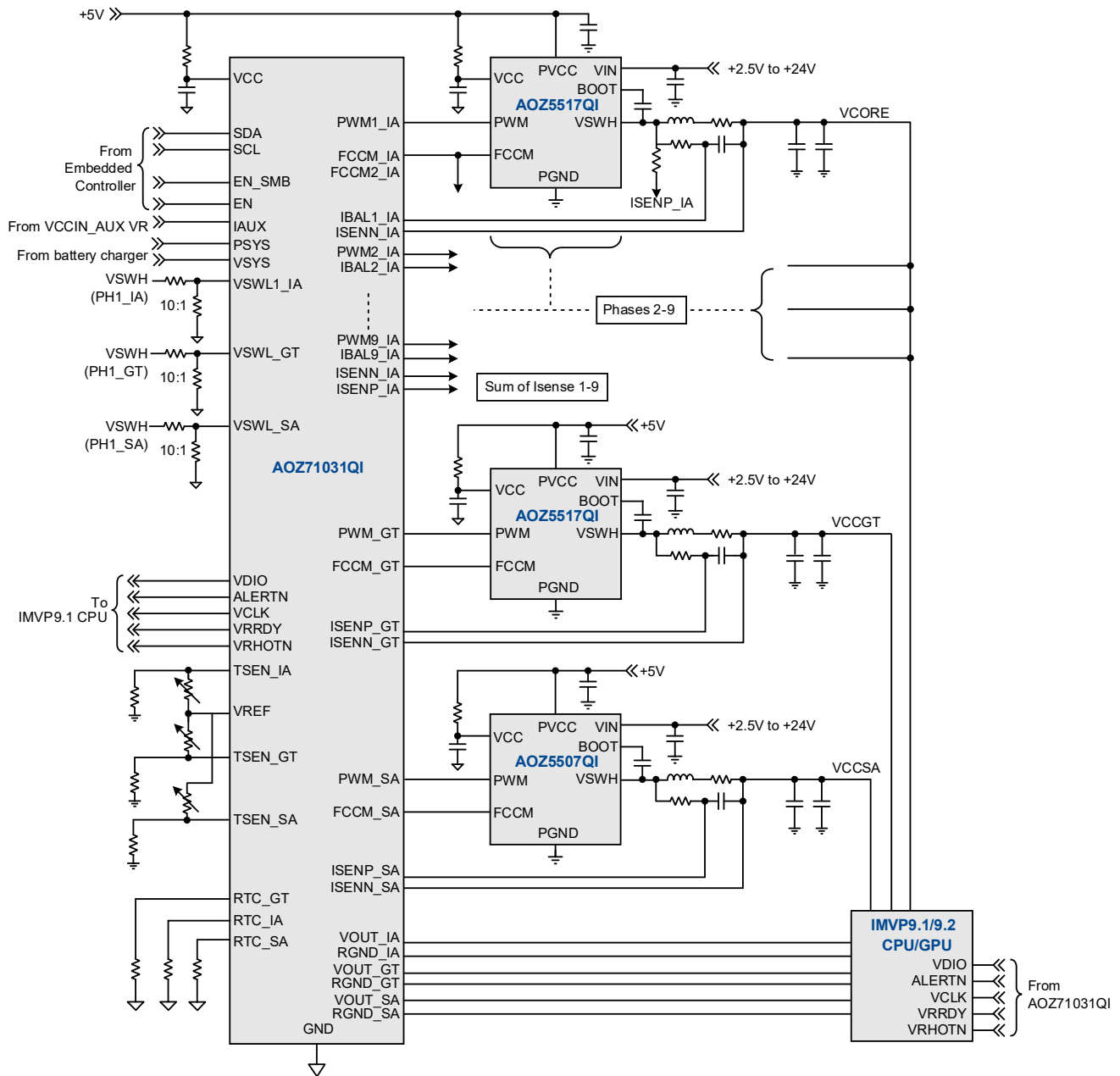

Figure 1. AOZ71031QI Typical Application Diagram

Ordering Information

Part Number ⁽¹⁾	Junction Temperature Range	Package	Environmental
AOZ71031QI-xxx ⁽²⁾	-40°C to +125°C	QFN7x7-60L	RoHS

Notes:

- For each customer, the full PN already created for order is on the last page of this DS. Please refer to last page for more information.
- “xxx” is the configuration code identifier (also called sub-part number) for the register settings stored in the internal non-volatile memory (NVM). Each “x” can be a value between 0 and 9 and A-Z (except I, J, O, Q). Please work with an AOS Sales/FAE to create this unique number. Each project or board might need to use different sub-PN as the register setting might be different.



AOS products are offered in packages with Pb-free plating and compliant to RoHS standards. Please visit <https://aosmd.com/sites/default/files/media/AOSGreenPolicy.pdf> for additional information.

Pin Configuration

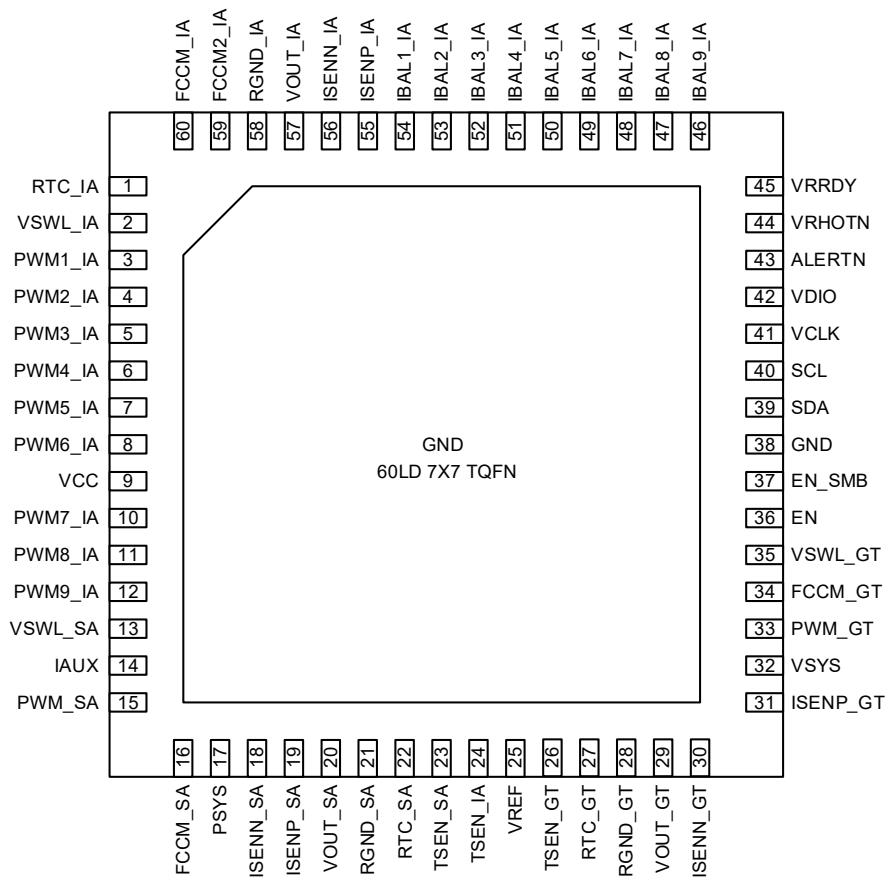
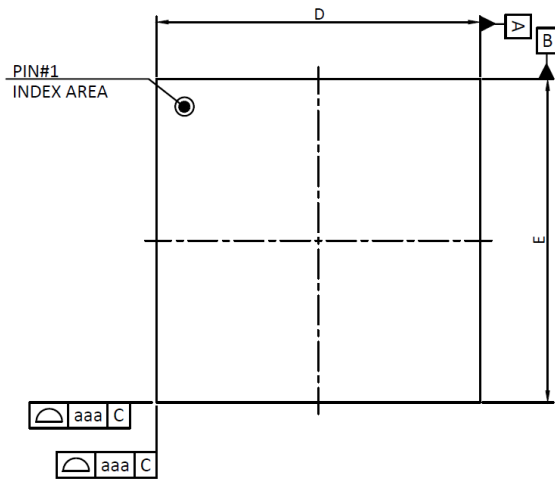
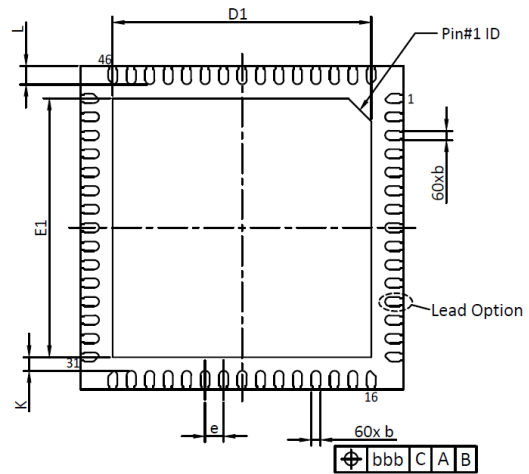

Figure 2. Pin Definition
QFN7x7-60L
(Top View)

Package Dimensions, QFN7x7-60L



TOP VIEW



BOTTOM VIEW

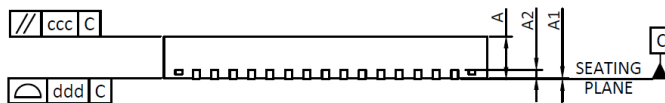

SIDE VIEW

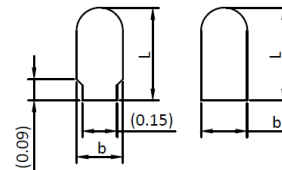

Option 1 Option 2

Lead Option

RECOMMENDED LAND PATTERN

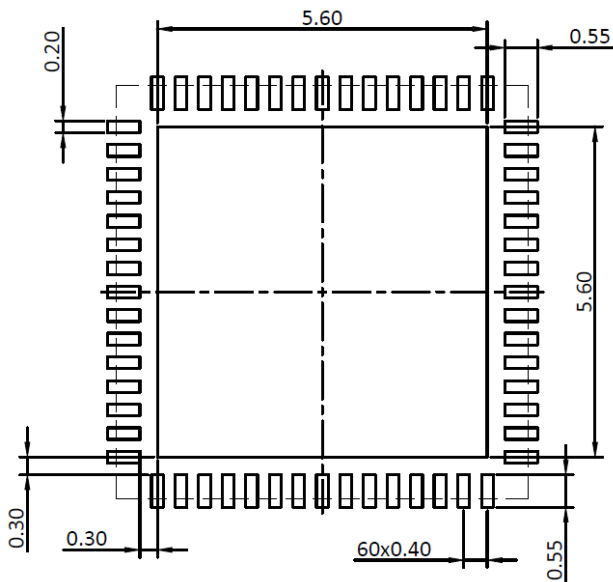

SYMBOLS	DIMENSION IN MM			DIMENSION IN INCHES		
	MIN	NOM	MAX	MIN	NOM	MAX
A	0.80	0.90	1.00	0.031	0.035	0.039
A1	0.00	0.02	0.05	0.000	0.001	0.002
A2	0.15	0.20	0.25	0.006	0.008	0.010
b	0.15	0.20	0.25	0.006	0.008	0.010
D	7.00 BSC			0.197 BSC		
D1	5.45	5.60	5.70	0.215	0.220	0.224
E	7.00 BSC			0.197 BSC		
E1	5.45	5.60	5.70	0.215	0.220	0.224
e	0.40 BSC			0.016 BSC		
K	0.20	0.30	0.40	0.008	0.012	0.016
L	0.30	0.40	0.50	0.012	0.016	0.020
aaa	0.10			0.004		
bbb	0.07			0.003		
ccc	0.10			0.004		
ddd	0.08			0.003		

UNIT: mm

NOTE:

1. CONTROLLING DIMENSION IS MILLIMETER.
2. CO-PLANARITY APPLIES TO THE EXPOSED PAD AND THE LEADS.

Tape and Reel Dimensions, QFN7x7-60L

QFN7x7 60L EP1 S Carrier Tape

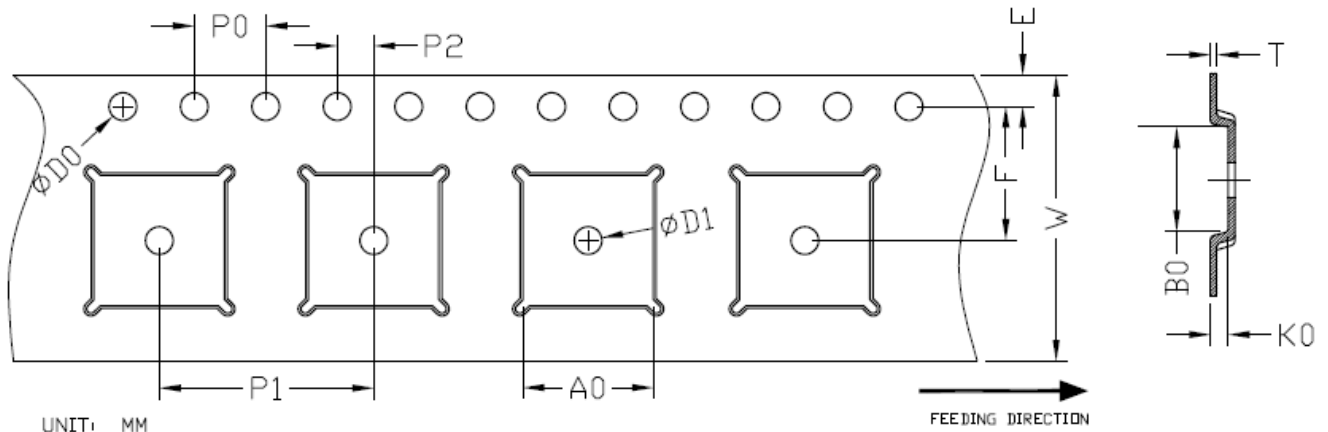

PACKAGE	A0	B0	K0	D0	D1	W	E	F	P0	P1	P2	T
QFN7x7	7,30 ±0,1	7,30 ±0,1	1,20 ±0,1	∅1,55 ±0,10	∅1,50 MIN.	16,00 $\begin{matrix} +0,3 \\ -0,1 \end{matrix}$	1,75 ±0,1	7,50 ±0,1	4,00 ±0,1	12,00 ±0,1	2,00 ±0,10	0,30 ±0,05

QFN7x7 60L EP1 S Reel

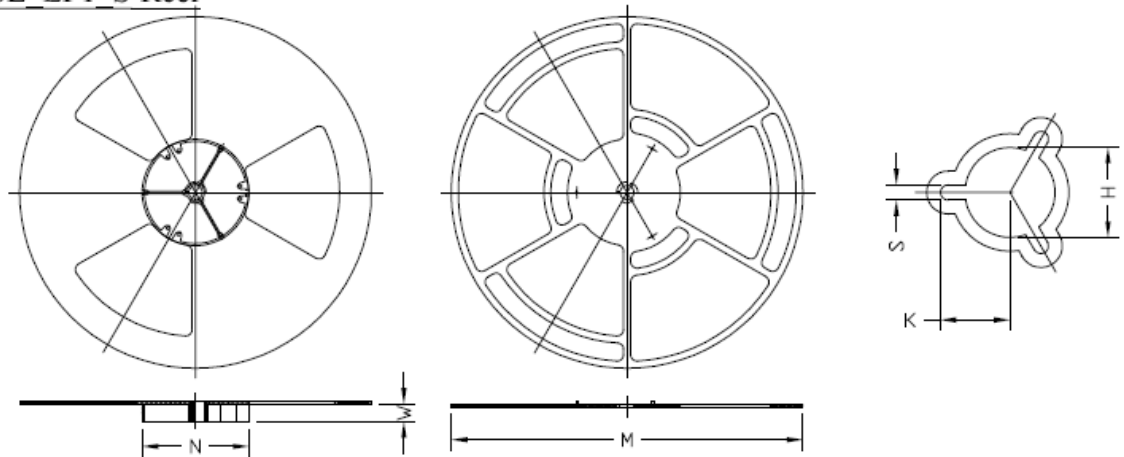

TAPE SIZE	REEL SIZE	M	N	W	H	K	S
16 mm	∅330	∅330,00 $\begin{matrix} +0,25 \\ -4,00 \end{matrix}$	∅100,00 ±0,2	16,4 $\begin{matrix} +2,0 \\ -0,0 \end{matrix}$	∅13,00 $\begin{matrix} +0,50 \\ -0,20 \end{matrix}$	10,5 ±0,25	2,2 ±0,25

QFN7x7 60L EP1 S Tape

Leader / Trailer
& Orientation

Unit Per Reel:
3000pcs

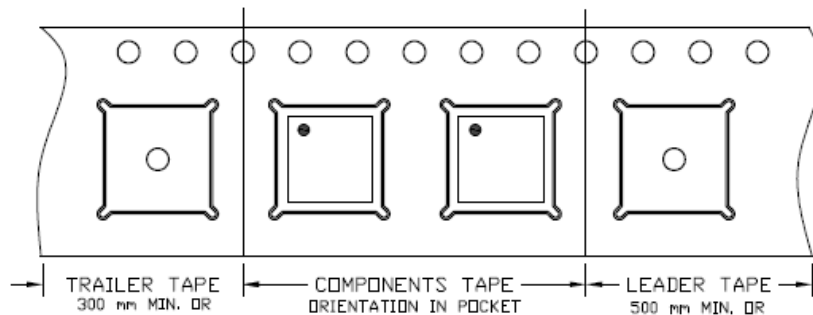

Part Marking

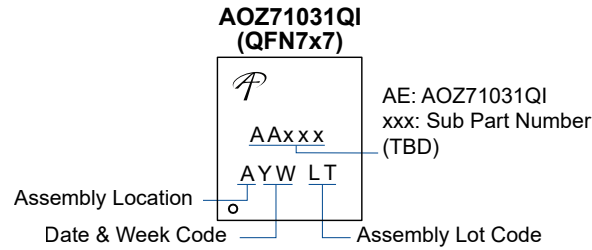

LEGAL DISCLAIMER

Applications or uses as critical components in life support devices or systems are not authorized. Alpha and Omega Semiconductor does not assume any liability arising out of such applications or uses of its products. AOS reserves the right to make changes to product specifications without notice. It is the responsibility of the customer to evaluate suitability of the product for their intended application. Customer shall comply with applicable legal requirements, including all applicable export control rules, regulations and limitations.

AOS's products are provided subject to AOS's terms and conditions of sale which are set forth at:
http://www.aosmd.com/terms_and_conditions_of_sale

LIFE SUPPORT POLICY

ALPHA AND OMEGA SEMICONDUCTOR PRODUCTS ARE NOT AUTHORIZED FOR USE AS CRITICAL COMPONENTS IN LIFE SUPPORT DEVICES OR SYSTEMS.

As used herein:

1. Life support devices or systems are devices or systems which, (a) are intended for surgical implant into the body or (b) support or sustain life, and (c) whose failure to perform device, or system whose failure to perform can be when properly used in accordance with instructions for use reasonably expected to cause the failure of the life support provided in the labeling, can be reasonably expected to device or system, or to affect its safety or effectiveness. result in a significant injury of the user.
2. A critical component in any component of a life support,